

bq27320 Single-Cell CEDV Fuel Gauge

1 Features

- Battery Fuel Gauge For System-/Pack-Side Configuration
- Compensated End-of-Discharge Voltage (CEDV) Gauging Technology
 - Adjusts for Battery Aging, Self-Discharge, Temperature, and Rate Changes
 - Reports Remaining Capacity, State-of-Charge (SOC), and Time-to-Empty with Smoothing Filter
 - Battery State-of-Health Estimation
 - Supports Embedded or Removable Packs from 100-mAhr to 14,500-mAhr Capacity
 - Accommodates Pack Swapping with up to Four Separate Battery Profiles
 - Supports a Raw Coulomb Counter To Provide Delta Capacity Information
- Microcontroller Peripheral Supports:
 - SDQ Communication Interface for Authentication ID
 - 400-kHz I²C™ Serial Interface for High-Speed Communication
 - 32 Bytes of Scratch-Pad FLASH NVM
 - Battery Low Digital Output Warning
 - Configurable SOC Interrupts
 - External Thermistor, Internal Sensor, or Host Reported Temperature Options
- 15-Pin 1.375 mm x 2.75 mm x 1.75 mm Pitch NanoFree™ (DSBGA) Package

2 Applications

- Smartphones, Feature Phones, and Tablets
- Wearables
- Building Automation
- Portable Medical/Industrial Handsets
- Portable Audio
- Gaming

3 Description

The Texas Instruments single-cell bq27320 battery fuel gauge requires very minimal configuration and system microcontroller firmware development, leading to quick system bring-up. The bq27320 uses the Compensated End-of-Discharge Voltage (CEDV) gas gauging algorithm for fuel gauging, and provides information such as remaining battery capacity (mAh), state-of-charge (%), runtime-to-empty (min), battery voltage (mV), temperature (°C) and state-of-health (%).

TI customers can tune chemistry parameters using TI's web-based tool, [GAUGEPARCAL](#).

Configurable interrupts help save system power and free up the host from continuous polling. Accurate temperature sensing is supported via an external thermistor.

Battery fuel gauging with the bq27320 requires only PACK+ (P+), PACK– (P–), and optional thermistor (T) connections to a removable battery pack or embedded battery circuit. The device uses a 15-ball NanoFree™ (DSBGA) package. It is ideal for space-constrained applications.

Device Information⁽¹⁾

PART NUMBER	PACKAGE	BODY SIZE (NOM)
bq27320	YZF (15)	1.375 mm x 2.75 mm x 1.75 mm

(1) For all available packages, see the orderable addendum at the end of the data sheet.

Simplified Schematic

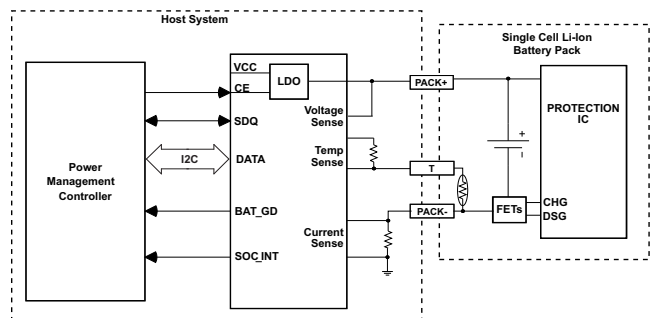

Table of Contents

1 Features	1	7.14 SDQ Switching Characteristics	7
2 Applications	1	7.15 Typical Characteristics	8
3 Description	1	8 Detailed Description	9
4 Revision History	2	8.1 Overview	9
5 Device Comparison Table	3	8.2 Functional Block Diagram	10
6 Pin Configuration and Functions	3	8.3 Feature Description	10
7 Specifications	4	8.4 Device Functional Modes	17
7.1 Absolute Maximum Ratings	4	9 Application and Implementation	18
7.2 ESD Ratings	4	9.1 Application Information	18
7.3 Recommended Operating Conditions	4	9.2 Typical Applications	19
7.4 Thermal Information	4	10 Power Supply Recommendations	23
7.5 Supply Current	5	10.1 Power Supply Decoupling	23
7.6 Digital Input and Output DC Characteristics	5	11 Layout	23
7.7 Power-On Reset	5	11.1 Layout Guidelines	23
7.8 2.5-V LDO Regulator	5	11.2 Layout Example	24
7.9 Internal Clock Oscillators	5	12 Device and Documentation Support	25
7.10 ADC (Temperature and Cell Measurement) Characteristics	6	12.1 Documentation Support	25
7.11 Integrating ADC (Coulomb Counter) Characteristics	6	12.2 Community Resources	25
7.12 Data Flash Memory Characteristics	6	12.3 Trademarks	25
7.13 I ² C-Compatible Interface Communication Timing Characteristics	7	12.4 Electrostatic Discharge Caution	25
		12.5 Glossary	25
		13 Mechanical, Packaging, and Orderable Information	25

4 Revision History

DATE	REVISION	NOTES
March 2016	A	PRODUCT PREVIEW to Production Data

5 Device Comparison Table

ORDER NUMBER	PACKAGE	PACKAGE QUANTITY	BODY SIZE
bq27320YZFT	YZF	250	1.375 mm x 2.75 mm x 1.75 mm
bq27320YZFR		3000	

6 Pin Configuration and Functions

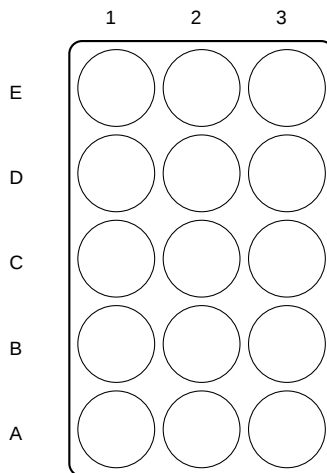

Pin Functions

PIN		TYPE	DESCRIPTION
NAME	NUMBER		
SRP	A1	IA ⁽¹⁾	Analog input pin connected to the internal coulomb counter with a Kelvin connection where SRP is nearest the PACK– connection. Connect to 5-mΩ to 20-mΩ sense resistor.
SRN	B1	IA	Analog input pin connected to the internal coulomb counter with a Kelvin connection where SRN is nearest the V _{SS} connection. Connect to 5-mΩ to 20-mΩ sense resistor.
V _{SS}	C1, C2	P	Device ground
V _{CC}	D1	P	Regulator output and bq27320 processor power. Decouple with 1-μF ceramic capacitor to V _{SS} .
REGIN	E1	P	Regulator input. Decouple with 0.1-μF ceramic capacitor to V _{SS} .
SOC_INT	A2	O	SOC state interrupts output. Generates a pulse under the conditions specified by ⁽¹⁾ . Open drain output
BAT_GD	B2	O	Battery Good push-pull indicator output. Active-low and output disabled by default. Polarity is configured via Op Config [BATG_POL] and the output is enabled via OpConfig C [BATGSPUEN] .
CE	D2	I	Chip Enable. Internal LDO is disconnected from REGIN when driven low. Note: CE has an internal ESD protection diode connected to REGIN. Recommend maintaining V _{CE} ≤ V _{REGIN} under all conditions.
BAT	E2	I	Cell-voltage measurement input. ADC input. Recommend 4.8V maximum for conversion accuracy.
SCL	A3	I	Slave I ² C serial communications clock input line for communication with system (Master). Open-drain I/O. Use with 10-kΩ pull-up resistor (typical).
SDA	B3	I/O	Slave I ² C serial communications data line for communication with system (Master). Open-drain I/O. Use with 10-kΩ pull-up resistor (typical).
SDQ	C3	O	Communication interface to Authentication ID IC, using the SDQ protocol
TS	D3	IA	Pack thermistor voltage sense (use 103AT-type thermistor). ADC input
BI/TOUT	E3	I/O	Battery-insertion detection input. Power pin for pack thermistor network. Thermistor-multiplexer control pin. Use with pull-up resistor >1MΩ (1.8 MΩ typical).

(1) I/O = Digital input/output, IA = Analog input, P = Power connection

7 Specifications

7.1 Absolute Maximum Ratings

 over operating free-air temperature range (unless otherwise noted)⁽¹⁾

		MIN	MAX	UNIT
V _{REGIN}	Regulator input range	-0.3	5.5	V
		-0.3	6.0 ⁽²⁾	V
V _{CE}	CE input pin	-0.3	V _{REGIN} + 0.3	V
V _{CC}	Supply voltage range	-0.3	2.75	V
V _{IOD}	Open-drain I/O pins (SDA, SCL, SOC_INT)	-0.3	5.5	V
V _{BAT}	BAT input pin	-0.3	5.5	V
		-0.3	6.0 ⁽²⁾	V
V _I	Input voltage range to all other pins (BI/TOUT, TS, SRP, SRN, SDQ, BAT_GD)	-0.3	V _{CC} + 0.3	V
T _A	Operating free-air temperature range	-40	85	°C
T _{FUNC}	Functional Temperature	-40	110	°C
T _{STG}	Storage temperature range	-65	150	°C

- (1) Stresses beyond those listed under "absolute maximum ratings" may cause permanent damage to the device. These are stress ratings only, and functional operation of the device at these or any other conditions beyond those indicated under "recommended operating conditions" is not implied. Exposure to absolute-maximum-rated conditions for extended periods may affect device reliability.
- (2) Condition not to exceed 100 hours at 25°C lifetime.

7.2 ESD Ratings

		VALUE	UNIT
V _(ESD)	Electrostatic Discharge	Human body model (HBM) ESD stress voltage ⁽¹⁾ , BAT pin	1500
		Human-body model (HBM), all other pins	2000
		Charged-device model (CDM) ESD stress voltage ⁽¹⁾	500

- (1) JEDEC document JEP157 states that 250-V CDM allows safe manufacturing with a standard ESD control process.

7.3 Recommended Operating Conditions

 T_A = -40°C to 85°C, V_{REGIN} = V_{BAT} = 3.6 V (unless otherwise noted)

		MIN	NOM	MAX	UNIT
V _{REGIN}	Supply voltage	No operating restrictions	2.8	4.5	V
		No FLASH writes	2.45	2.8	
C _{REGIN}	External input capacitor for internal LDO between REGIN and V _{SS}	Nominal capacitor values specified. Recommend a 5% ceramic X5R type capacitor located close to the device.		0.1	μF
C _{LDO25}	External output capacitor for internal LDO between V _{CC} and V _{SS}	0.47	1		μF
t _{PUCD}	Power-up communication delay	250			ms

7.4 Thermal Information

THERMAL METRIC ⁽¹⁾		bq27320		UNIT
		YZF (DSBGA)		
		15 PINS		
R _{θJA}	Junction-to-ambient thermal resistance	70		°C/W
R _{θJctop}	Junction-to-case (top) thermal resistance	17		°C/W
R _{θJB}	Junction-to-board thermal resistance	20		°C/W
Ψ _{JT}	Junction-to-top characterization parameter	1		°C/W
Ψ _{JB}	Junction-to-board characterization parameter	18		°C/W
R _{θJcbot}	Junction-to-case (bottom) thermal resistance	n/a		°C/W

- (1) For more information about traditional and new thermal metrics, see the IC Package Thermal Metrics application report, [SPRA953](#)

7.5 Supply Current

 $T_A = 25^\circ\text{C}$ and $V_{\text{REGIN}} = V_{\text{BAT}} = 3.6\text{ V}$ (unless otherwise noted)

PARAMETER		TEST CONDITIONS	MIN	TYP	MAX	UNIT
$I_{\text{CC}}^{(1)}$	Normal operating-mode current	Fuel gauge in NORMAL mode $I_{\text{LOAD}} > \text{Sleep Current}$		118		μA
$I_{\text{SNOOZE}}^{(1)}$	Sleep+ operating mode current	Fuel gauge in SNOOZE mode $I_{\text{LOAD}} < \text{Sleep Current}$		62		μA
$I_{\text{SLP}}^{(1)}$	Low-power storage-mode current	Fuel gauge in SLEEP mode $I_{\text{LOAD}} < \text{Sleep Current}$		23		μA
$I_{\text{HIB}}^{(1)}$	Hibernate operating-mode current	Fuel gauge in HIBERNATE mode $I_{\text{LOAD}} < \text{Hibernate Current}$		8		μA
$I_{\text{SHD}}^{(1)}$	SHUTDOWN mode current	Fuel gauge in SHUTDOWN mode CE Pin $< V_{\text{IL(CE) max}}$.		1		μA

(1) Specified by design. Not production tested.

7.6 Digital Input and Output DC Characteristics

 $T_A = -40^\circ\text{C}$ to 85°C , typical values at $T_A = 25^\circ\text{C}$ and $V_{\text{REGIN}} = 3.6\text{ V}$ (unless otherwise noted)

PARAMETER		TEST CONDITIONS	MIN	TYP	MAX	UNIT
V_{OL}	Output voltage, low (SCL, SDA, SOC_INT, SDQ, BAT_GD)	$I_{\text{OL}} = 3\text{ mA}$			0.4	V
$V_{\text{OH(PP)}}$	Output voltage, high (SDQ, BAT_GD)	$I_{\text{OH}} = -1\text{ mA}$	$V_{\text{CC}} - 0.5$			V
$V_{\text{OH(OD)}}$	Output voltage, high (SDA, SCL, SOC_INT)	External pullup resistor connected to V_{CC}	$V_{\text{CC}} - 0.5$			V
V_{IL}	Input voltage, low (SDA, SCL)		-0.3		0.6	V
	Input voltage, low (BI/TOUT)	BAT INSERT CHECK mode active	-0.3		0.6	V
V_{IH}	Input voltage, high (SDA, SCL)		1.2			V
	Input voltage, high (BI/TOUT)	BAT INSERT CHECK mode active	1.2	$V_{\text{CC}} + 0.3$		V
$V_{\text{IL(CE)}}$	Input voltage, low (CE)	$V_{\text{REGIN}} = 2.8$ to 4.5 V			0.8	V
$V_{\text{IH(CE)}}$	Input voltage, high (CE)		2.65			V
$I_{\text{IKG}}^{(1)}$	Input leakage current (I/O pins)				0.3	μA

(1) Specified by design. Not production tested.

7.7 Power-On Reset

 $T_A = -40^\circ\text{C}$ to 85°C , typical values at $T_A = 25^\circ\text{C}$ and $V_{\text{REGIN}} = 3.6\text{ V}$ (unless otherwise noted)

PARAMETER		TEST CONDITIONS	MIN	TYP	MAX	UNIT
$V_{\text{IT+}}$	Positive-going battery voltage input at V_{CC}		2.05	2.15	2.20	V
V_{HYS}	Power-on reset hysteresis			115		mV

7.8 2.5-V LDO Regulator

 $T_A = -40^\circ\text{C}$ to 85°C , $C_{\text{LDO25}} = 1\mu\text{F}$, $V_{\text{REGIN}} = 3.6\text{ V}$ (unless otherwise noted)

PARAMETER		TEST CONDITIONS	MIN	NOM	MAX	UNIT
V_{REG25}	Regulator output voltage (V_{CC})	$2.8\text{ V} \leq V_{\text{REGIN}} \leq 4.5\text{ V}$, $I_{\text{OUT}} \leq 16\text{ mA}^{(1)}$	2.3	2.5	2.6	V
		$2.45\text{ V} \leq V_{\text{REGIN}} < 2.8\text{ V}$ (low battery), $I_{\text{OUT}} \leq 3\text{ mA}$	2.3			V

(1) LDO output current, I_{OUT} , is the total load current. LDO regulator should be used to power internal fuel gauge only.

7.9 Internal Clock Oscillators

 $T_A = -40^\circ\text{C}$ to 85°C , $2.4\text{ V} < V_{\text{CC}} < 2.6\text{ V}$; typical values at $T_A = 25^\circ\text{C}$ and $V_{\text{CC}} = 2.5\text{ V}$ (unless otherwise noted)

PARAMETER		TEST CONDITIONS	MIN	TYP	MAX	UNIT
f_{OSC}	High Frequency Oscillator			8.389		MHz

Internal Clock Oscillators (continued)

 $T_A = -40^{\circ}\text{C}$ to 85°C , $2.4\text{ V} < V_{CC} < 2.6\text{ V}$; typical values at $T_A = 25^{\circ}\text{C}$ and $V_{CC} = 2.5\text{ V}$ (unless otherwise noted)

PARAMETER	TEST CONDITIONS	MIN	TYP	MAX	UNIT
f_{LOSC}	Low Frequency Oscillator		32.768		kHz

7.10 ADC (Temperature and Cell Measurement) Characteristics

 $T_A = -40^{\circ}\text{C}$ to 85°C , $2.4\text{ V} < V_{CC} < 2.6\text{ V}$; typical values at $T_A = 25^{\circ}\text{C}$ and $V_{CC} = 2.5\text{ V}$ (unless otherwise noted)

PARAMETER	TEST CONDITIONS	MIN	TYP	MAX	UNIT
V_{ADC1}	Input voltage range (TS)	$V_{SS} - 0.125$		2	V
V_{ADC2}	Input voltage range (BAT)	$V_{SS} - 0.125$		5	V
$V_{\text{IN(ADC)}}$	Input voltage range	0.05		1	V
G_{TEMP}	Internal temperature sensor voltage gain		-2		mV/°C
$t_{\text{ADC_CONV}}$	Conversion time			125	ms
	Resolution	14		15	bits
$V_{\text{OS(ADC)}}$	Input offset		1		mV
$Z_{\text{ADC1}}^{(1)}$	Effective input resistance (TS)	8			MΩ
$Z_{\text{ADC2}}^{(1)}$	Effective input resistance (BAT)	bq27320 not measuring cell voltage	8		MΩ
		bq27320 measuring cell voltage		100	kΩ
$I_{\text{lkq(ADC)}}^{(1)}$	Input leakage current			0.3	μA

(1) Specified by design. Not tested in production.

7.11 Integrating ADC (Coulomb Counter) Characteristics

 $T_A = -40^{\circ}\text{C}$ to 85°C , $2.4\text{ V} < V_{CC} < 2.6\text{ V}$; typical values at $T_A = 25^{\circ}\text{C}$ and $V_{CC} = 2.5\text{ V}$ (unless otherwise noted)

PARAMETER	TEST CONDITIONS	MIN	TYP	MAX	UNIT	
V_{SR}	Input voltage range, $V_{\text{(SRP)}}$ and $V_{\text{(SRN)}}$	$V_{\text{SR}} = V_{\text{(SRP)}} - V_{\text{(SRN)}}$		-0.125	0.125	V
$t_{\text{SR_CONV}}$	Conversion time	Single conversion	1		s	
	Resolution		14	15	bits	
$V_{\text{OS(SR)}}$	Input offset		10		μV	
INL	Integral nonlinearity error		±0.007%	±0.034%	FSR	
$Z_{\text{IN(SR)}}^{(1)}$	Effective input resistance	2.5			MΩ	
$I_{\text{lkq(SR)}}^{(1)}$	Input leakage current			0.3	μA	

(1) Specified by design. Not tested in production.

7.12 Data Flash Memory Characteristics

 $T_A = -40^{\circ}\text{C}$ to 85°C , $2.4\text{ V} < V_{CC} < 2.6\text{ V}$; typical values at $T_A = 25^{\circ}\text{C}$ and $V_{CC} = 2.5\text{ V}$ (unless otherwise noted)

PARAMETER	TEST CONDITIONS	MIN	TYP	MAX	UNIT
$t_{\text{DR}}^{(1)}$	Data retention	10			Years
	Flash-programming write cycles ⁽¹⁾	20,000			Cycles
$t_{\text{WORDPROG}}^{(1)}$	Word programming time			2	ms
$I_{\text{CCPROG}}^{(1)}$	Flash-write supply current		5	10	mA
$t_{\text{DFERASE}}^{(1)}$	Data flash master erase time	200			ms
$t_{\text{IFERASE}}^{(1)}$	Instruction flash master erase time	200			ms
$t_{\text{PGERASE}}^{(1)}$	Flash page erase time	20			ms

(1) Specified by design. Not production tested

7.13 I²C-Compatible Interface Communication Timing Characteristics

$T_A = -40^{\circ}\text{C}$ to 85°C , $2.4\text{ V} < V_{CC} < 2.6\text{ V}$; typical values at $T_A = 25^{\circ}\text{C}$ and $V_{CC} = 2.5\text{ V}$ (unless otherwise noted)

PARAMETER	TEST CONDITIONS	MIN	NOM	MAX	UNIT
t_r	SCL/SDA rise time			300	ns
t_f	SCL/SDA fall time			300	ns
$t_{w(H)}$	SCL pulse duration (high)	600			ns
$t_{w(L)}$	SCL pulse duration (low)	1.3			μs
$t_{su(STA)}$	Setup for repeated start	600			ns
$t_{d(STA)}$	Start to first falling edge of SCL	600			ns
$t_{su(DAT)}$	Data setup time	100			ns
$t_{h(DAT)}$	Data hold time	0			ns
$t_{su(STOP)}$	Setup time for stop	600			ns
$t_{(BUF)}$	Bus free time between stop and start	66			μs
f_{SCL}	Clock frequency ⁽¹⁾			400	kHz

(1) If the clock frequency (f_{SCL}) is $> 100\text{ kHz}$, use 1-byte write commands for proper operation. All other transactions types are supported at 400 kHz. (Refer to [I²C Interface](#) and [I²C Command Waiting Time](#))

7.14 SDQ Switching Characteristics

$T_A = -20^{\circ}\text{C}$ to 70°C ; $V_{PU(min)} = 2.65\text{ V}_{DC}$ to 5.5 V_{DC} , all voltages relative to VSS

PARAMETER	TEST CONDITIONS	MIN	TYP	MAX	UNIT
t_c	Bit cycle time ⁽¹⁾	60		120	μs
t_{WSTRB}	Write start cycle ⁽¹⁾	1		15	μs
t_{WDSU}	Write data setup ⁽¹⁾	t_{WSTRB}		15	μs
t_{WDH}	Write data hold ^{(1) (2)}	60		t_c	μs
t_{rec}	Recovery time ⁽¹⁾		1		μs
		For memory command only	5		
t_{RSTRB}	Read start cycle ⁽¹⁾	1		13	μs
t_{ODD}	Output data delay ⁽¹⁾	t_{RSTRB}		13	μs
t_{ODHO}	Output data hold ⁽¹⁾	17		60	μs
t_{RST}	Reset time ⁽¹⁾	480			μs
t_{PPD}	Presence pulse delay ⁽¹⁾	15		60	μs
t_{PP}	Presence pulse ⁽¹⁾	60		240	μs
t_{EPROG}	EPROM programming time	2500			μs
t_{PSU}	Program setup time	5			μs
t_{PREC}	Program recovery time	5			μs
t_{PRE}	Program rising-edge time			5	μs
t_{PFE}	Program falling-edge time			5	μs
t_{RSTREC}		480			μs

(1) 5-k Ω series resistor between SDQ pin and V_{PU} .

(2) t_{WDH} must be less than t_c to account for recovery.

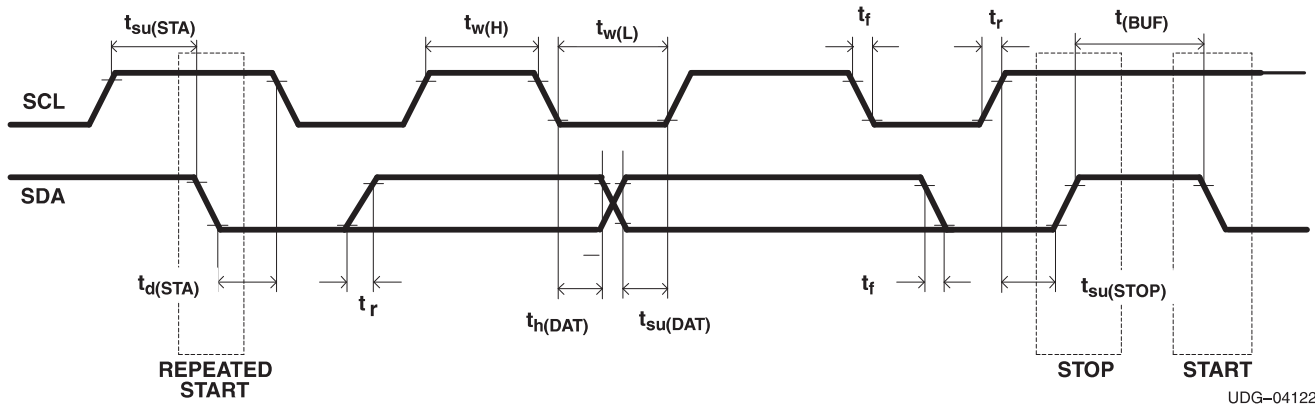

Figure 1. I²C-Compatible Interface Timing Diagrams

7.15 Typical Characteristics

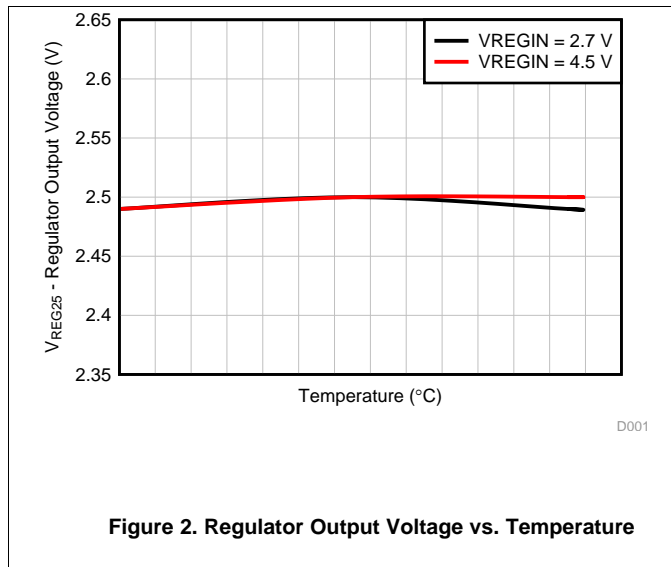

Figure 2. Regulator Output Voltage vs. Temperature

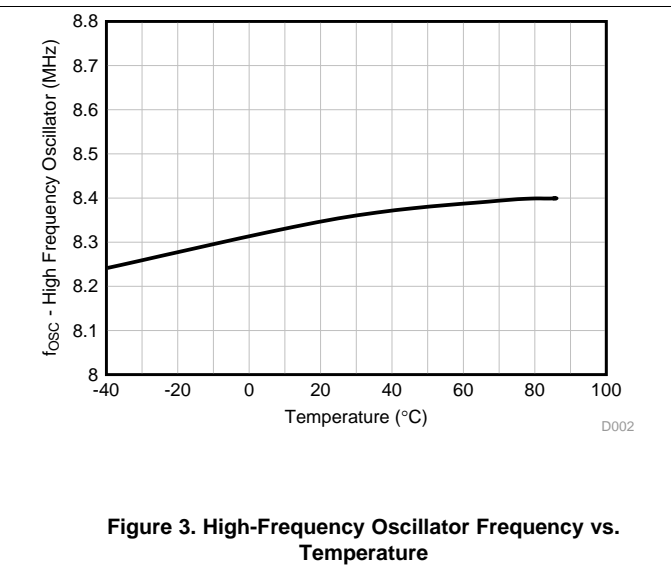

Figure 3. High-Frequency Oscillator Frequency vs. Temperature

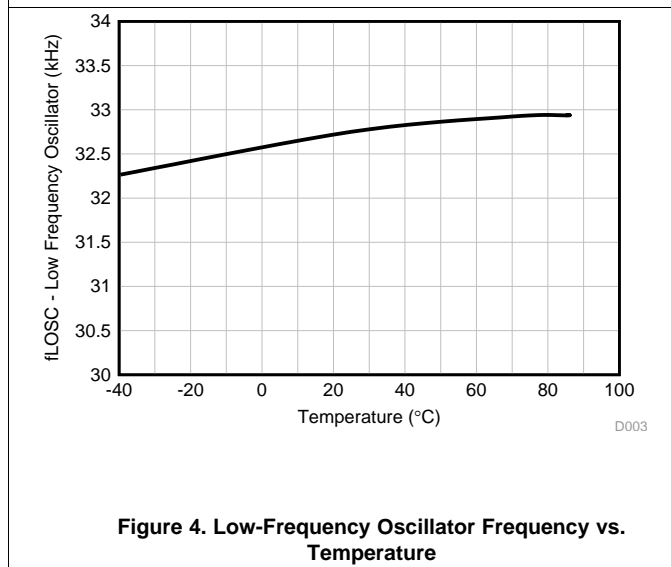

Figure 4. Low-Frequency Oscillator Frequency vs. Temperature

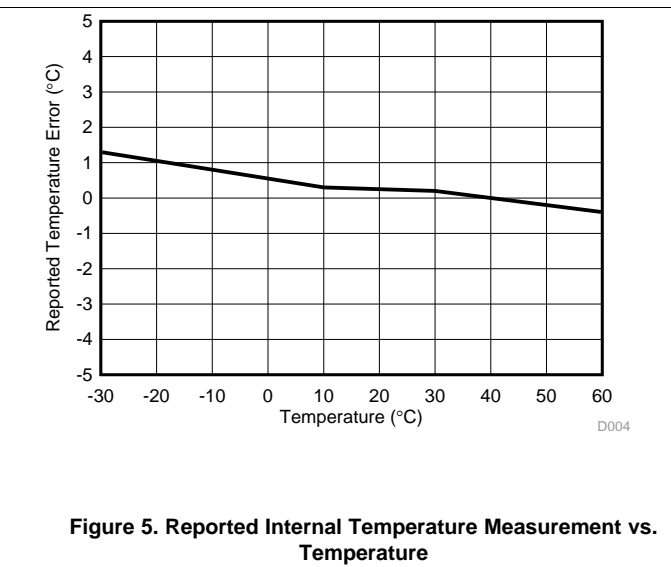

Figure 5. Reported Internal Temperature Measurement vs. Temperature

8 Detailed Description

8.1 Overview

The bq27320 measures the voltage, temperature, and current to determine battery capacity and state of charge (SOC). The bq27320 monitors charge and discharge activity by sensing the voltage across a small-value resistor (5 mΩ to 20 mΩ typical) between the SRP and SRN pins and in series with the battery. By integrating charge passing through the battery, the battery's SOC is adjusted during battery charge or discharge.

Measurements of OCV and charge integration determine chemical state of charge. The Qmax values are taken from a cell manufacturers' data sheet multiplied by the number of parallel cells. It is also used for the value in **Design Capacity**. It uses the OCV and Qmax value to determine *StateOfCharge()* on battery insertion, device reset, or on command. The *FullChargeCapacity()* is reported as the learned capacity available from full charge until *Voltage()* reaches the EDV0 threshold.

As *Voltage()* falls below the **SysDown Set Volt Threshold**, the *Flags()* [SYSDOWN] bit is set and SOC_INT will toggle once to provide a final warning to shut down the system. As *Voltage()* rises above **SysDown Clear Voltage** the [SYSDOWN] bit is cleared.

Additional details are found in the *bq27320 Technical Reference Manual* ([SLUUBE6](#)).

The fuel gauging is derived from the Compensated End of Discharge Voltage (CEDV) method, which uses a mathematical model to correlate remaining state of charge (RSOC) and voltage near to the end of discharge state. This requires a full discharge cycle for a single point FCC update. The implementation models cell voltage (OCV) as a function of battery state of charge (SOC), temperature, and current. The impedance is also a function of SOC and temperature, all of which can be satisfied by using seven parameters: EMF, C0, R0, T0, R1, TC, C1. For more detailed information, contact TI Applications Support at <http://www-k.ext.ti.com/sc/technical-support/email-tech-support.asp?AAP>.

8.2 Functional Block Diagram

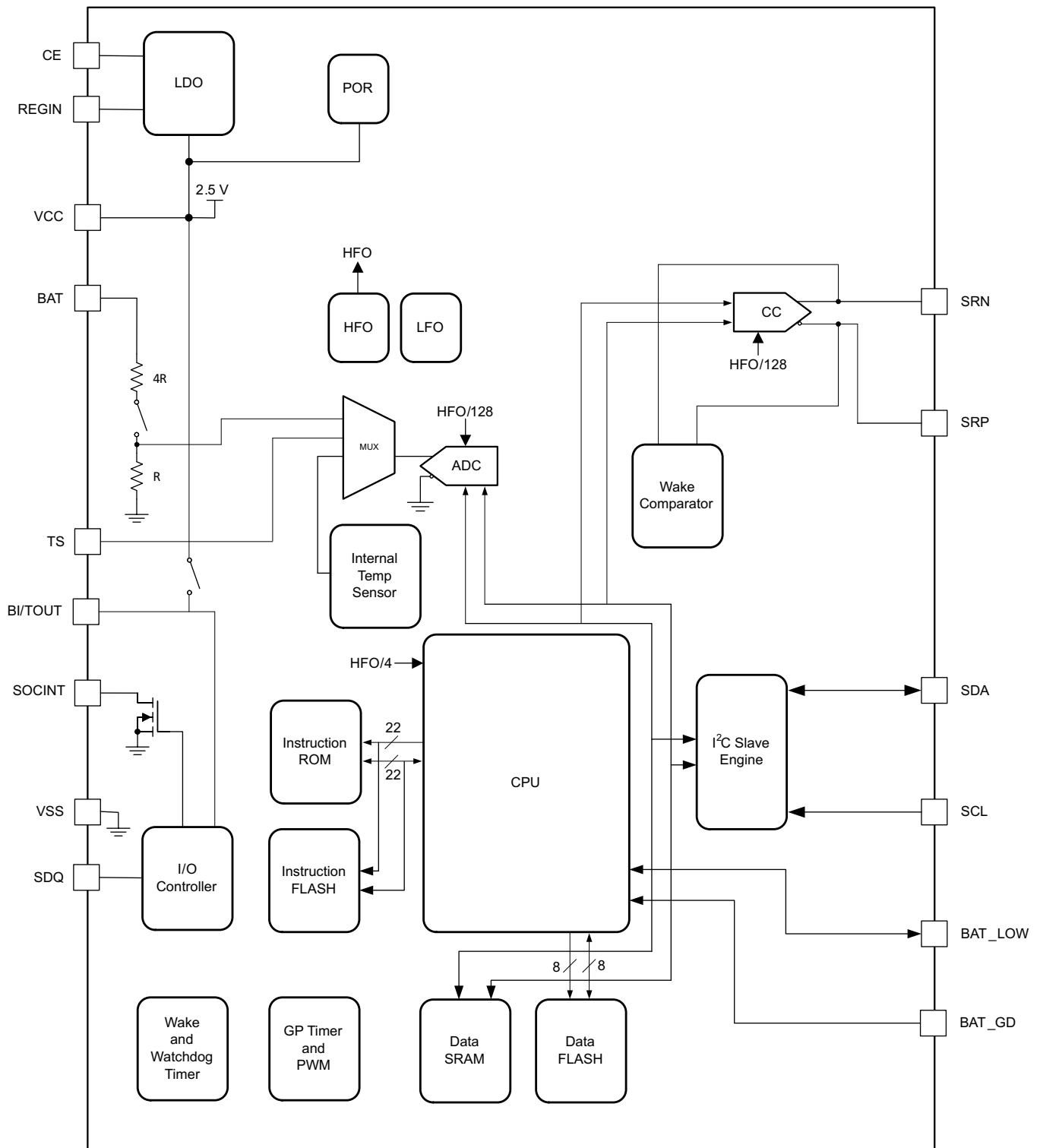

8.3 Feature Description

The bq27320 accurately predicts the battery capacity and other operational characteristics of a single Li-based rechargeable cell. It can be interrogated by a system processor to provide cell information, such as time-to-empty (TTE) and state-of-charge (SOC) as well as SOC interrupt signal to the host.

Feature Description (continued)

Information is accessed through a series of commands, called *Standard Commands*. Further capabilities are provided by the additional *Manufacturer Access Control* subcommand set. Both sets of commands, indicated by the general format *Command()*, are used to read and write information contained within the device control and status registers, as well as its data flash locations. Commands are sent from system to gauge using the bq27320 device's I²C serial communications engine, and can be executed during application development, system manufacture, or end-equipment operation.

Cell information is stored in the device in non-volatile flash memory. Many of these data flash locations are accessible during application development. They cannot, generally, be accessed directly during end-equipment operation. Access to these locations is achieved by either use of the bq27320 device's companion evaluation software, through individual commands, or through a sequence of data-flash-access commands. To access a desired data flash location, the correct data flash address must be known.

The key to the bq27320 device's high-accuracy gas gauging prediction is Texas Instruments CEDV algorithm. This algorithm uses cell measurements, characteristics, and properties to create state-of-charge predictions across a wide variety of operating conditions and over the lifetime of the battery.

The device measures charge and discharge activity by monitoring the voltage across a small-value series sense resistor (5 mΩ to 20 mΩ typical) located between the system's V_{SS} and the battery's PACK– pin. When a cell is attached to the device, FCC is learned based on cell current and on cell voltage under-loading conditions when the EDV2 threshold is reached.

The device external temperature sensing is optimized with the use of a high accuracy negative temperature coefficient (NTC) thermistor with R₂₅ = 10.0 kΩ ±1%. B_{25/85} = 3435K ± 1% (such as Semitec NTC 103AT). Alternatively, the bq27320 can also be configured to use its internal temperature sensor or receive temperature data from the host processor. When an external thermistor is used, a 18.2-kΩ pull-up resistor between BI/TOUT and TS pins is also required. The bq27320 uses temperature to monitor the battery-pack environment, which is used for fuel gauging and cell protection functionality.

To minimize power consumption, the device has different power modes: NORMAL, SNOOZE, SLEEP, HIBERNATE, and BAT INSERT CHECK. The bq27320 passes automatically between these modes, depending upon the occurrence of specific events, though a system processor can initiate some of these modes directly.

For complete operational details, refer to the *bq27320 Technical Reference Manual* ([SLUUBE6](#)).

NOTE

Formatting Conventions in this Document:

Commands: *italics* with parentheses() and no breaking spaces; for example, *RemainingCapacity()*

Data Flash: *italics*, **bold**, and breaking spaces; for example, ***Design Capacity***

Register bits and flags: *italics* with brackets []; for example, *[TDA]*

Data flash bits: *italics*, **bold**, and brackets []; for example, ***[LED1]***

Modes and states: ALL CAPITALS, for example; UNSEALED mode

8.3.1 Data Commands

8.3.1.1 Standard Data Commands

The bq27320 uses a series of 2-byte standard commands to enable system reading and writing of battery information. Each standard command has an associated command-code pair, as indicated in [Table 1](#) (see the *bq27320 Technical Reference Manual* [[SLUUBE6](#)]). Because each command consists of two bytes of data, two consecutive I²C transmissions must be executed both to initiate the command function, and to read or write the corresponding two bytes of data.

Feature Description (continued)
Table 1. Standard Commands

NAME		COMMAND CODE	UNIT	SEALED ACCESS
<i>Control()</i> / <i>CONTROL_STATUS()</i>	CNTL	0x00 and 0x01	NA	RW
<i>AtRate()</i>	AR	0x02 and 0x03	mA	RW
<i>AtRateTimeToEmpty()</i>	ARTTE	0x04 and 0x05	Minutes	R
<i>Temperature()</i>	TEMP	0x06 and 0x07	0.1°K	RW
<i>Voltage()</i>	VOLT	0x08 and 0x09	mV	R
<i>BatteryStatus()</i>	<i>Flags()</i>	0x0A and 0x0B	NA	R
<i>Current()</i>	<i>Current()</i>	0x0C and 0x0D	mAh	R
<i>RemainingCapacity()</i>	RM	0x10 and 0x11	mAh	R
<i>FullChargeCapacity()</i>	FCC	0x12 and 0x13	mAh	R
<i>AverageCurrent()</i>	AI	0x14 and 0x15	mA	R
<i>TimeToEmpty()</i>	TTE	0x16 and 0x17	Minutes	R
<i>TimeToFull()</i>	TTF	0x18 and 0x19	Minutes	R
<i>StandbyCurrent()</i>	SI	0x1A and 0x1B	mA	R
<i>StandbyTimeToEmpty()</i>	STTE	0x1C and 0x1D	Minutes	R
<i>MaxLoadCurrent()</i>	MLI	0x1E and 0x1F	mA	R
<i>MaxLoadTimeToEmpty()</i>	MLTTE	0x20 and 0x21	min	R
<i>AveragePower()</i>	AP	0x24 and 0x25	mW	R
<i>InternalTemperature()</i>	INTTEMP	0x28 and 0x29	0.1°K	R
<i>CycleCount()</i>	CC	0x2A and 0x2B	num	R
<i>StateOfCharge()</i>	SOC	0x2C and 0x2D	—	R
<i>StateOfHealth()</i>	SOH	0x2E and 0x2F	num	R
<i>ChargeVoltage()</i>	CV	0x30 and 0x31	mV	R
<i>ChargeCurrent()</i>	CC	0x32 and 0x33	mA	R
<i>BTPDischargeSet()</i>		0x34 and 0x35	mAh	R
<i>BTPChargeSet()</i>		0x36 and 0x37	mAh	R
<i>OperationStatus()</i>		0x3A and 0x3B	NA	R
<i>DesignCapacity()</i>	Design Cap	0x3C and 0x3D	mAh	R
<i>ManufacturerAccessControl()</i>	MAC	0x3E and 0x3F		
<i>MACData()</i>		0x40 through 0x5F		
<i>MACDataSum()</i>		0x60		
<i>MACDataLen()</i>		0x61		
<i>AnalogCount()</i>		0x79		
<i>RawCurrent()</i>		0x7A and 0x7B		
<i>RawVoltage()</i>		0x7C and 0x7D		
<i>RawIntTemp()</i>		0x7E and 0x7F		
<i>RawExtTemp()</i>		0x80 and 0x81		

8.3.1.1.1 Control(): 0x00/0x01

Issuing a *Control()* (Manufacturer Access Control or MAC) command requires a 2-byte subcommand. The subcommand specifies the particular MAC function desired. The *Control()* command allows the system to control specific features of the gas gauge during normal operation and additional features when the device is in different access modes, as described in the *bq27320 Technical Reference Manual (SLUUBE6)*.

Table 2. Control() MAC Subcommands

CNTL / MAC FUNCTION	SUBCOMMAND CODE	SEALED ACCESS?	DESCRIPTION
CONTROL_STATUS	0x0000	Yes	Ignored by gauge (in previous devices would enable <i>CONTROL_STATUS()</i> read).
DEVICE_TYPE	0x0001	Yes	Reports the device type (for example: 0x0320)
FW_VERSION	0x0002	Yes	Reports the firmware version block (device, version, build, and so on)
HW_VERSION	0x0003	Yes	Reports the hardware version of the device
IF_SUM	0x0004	Yes	Reports Instruction flash checksum
STATIC_DF_SUM	0x0005	Yes	Reports the static data flash checksum
CHEM_ID	0x0006	Yes	Reports the chemical identifier of the CEDV configuration
PREV_MACWRITE	0x0007	Yes	Returns previous <i>Control()</i> subcommand code
STATIC_CHEM_DF_SUM	0x0008	Yes	Returns the chem ID checksum
BOARD_OFFSET	0x0009	Yes	Invokes the board offset correction
CC_OFFSET	0x000A	Yes	Invokes the CC offset correction
CC_OFFSET_SAVE	0x000B	Yes	Saves the results of the offset calibration process
OCV_CMD	0x000C	Yes	Requests the gas gauge to take an OCV measurement
BAT_INSERT	0x000D	Yes	Forces <i>BatteryStatus()[BATTPRES]</i> bit set when Operation Config B [BIEnable] bit = 0
BAT_REMOVE	0x000E	Yes	Forces <i>BatteryStatus()[BATTPRES]</i> bit clear when Operation Config B [BIEnable] bit = 0
ALL_DF_SUM	0x0010	Yes	Returns the checksum of the entire data flash except for calibration data
SET_HIBERNATE	0x0011	Yes	Forces <i>CONTROL_STATUS()[HIBERNATE]</i> bit to 1
CLEAR_HIBERNATE	0x0012	Yes	Forces <i>CONTROL_STATUS()[HIBERNATE]</i> bit to 0
SET_SNOOZE	0x0013	Yes	Forces <i>CONTROL_STATUS()[SNOOZE]</i> bit to 1
CLEAR_SNOOZE	0x0014	Yes	Forces <i>CONTROL_STATUS()[SNOOZE]</i> bit to 0
BATT_SELECT_0	0x0015	Yes	Select Battery Profile 0
BATT_SELECT_1	0x0016	Yes	Select Battery Profile 1
BATT_SELECT_2	0x0017	Yes	Select Battery Profile 2
BATT_SELECT_3	0x0018	Yes	Select Battery Profile 3
CAL_MODE	0x002D	No	Toggles <i>OperationStatus()[CALMD]</i>
SEALED	0x0030	No	Places the gas gauge in SEALED access mode
SECURITY_KEYS	0x0035	No	Read and Write Security Keys
RESET	0x0041	No	Resets device
DEVICE_NAME	0x004a	Yes	Returns the device name
OPERATION_STATUS	0x0054	Yes	This returns the same value as the <i>OperationStatus()</i> register.
GaugingStatus	0x0056	Yes	Returns the information of CEDV gauge module status register
MANU_DATA	0x0070	Yes	Returns the manufacturer info A block. This can be written directly when unsealed
GGSTATUS1	0x0073	Yes	Returns internal gauge debug data block 1
GGSTATUS2	0x0074	Yes	Returns internal gauge debug data block 2
GGSTATUS3	0x0075	Yes	Returns internal gauge debug data block 3
GGSTATUS4	0x0076	Yes	Returns internal gauge debug data block 4
EXIT_CAL	0x0080	No	Instructs the fuel gauge to exit calibration mode
ENTER_CAL	0x0081	No	Instructs the fuel gauge to enter calibration mode
RETURN_TO_ROM	0xF00	No	Places the device in ROM mode
DF_ADDR_START	0x4000	No	Direct DF read write access boundary
DF_ADDR_END	0x43FF	No	DF read write access boundary

8.3.2 SDQ Signaling

All SDQ signaling begins with initializing the device, followed by the host driving the bus low to write a 1 or 0, or to begin the start frame for a bit read. [Figure 6](#) shows the initialization timing, whereas [Figure 7](#) and [Figure 8](#) show that the host initiates each bit by driving the DATA bus low for the start period, t_{WSTRB} / t_{RSTRB} . After the bit is initiated, either the host continues controlling the bus during a WRITE, or the bq27320 responds during a READ.

8.3.3 Reset and Presence Pulse

If the DATA bus is driven low for more than 120 μ s, the bq27320 may be reset. [Figure 6](#) shows that if the DATA bus is driven low for more than 480 μ s, the bq27320 resets and indicates that it is ready by responding with a PRESENCE PULSE.

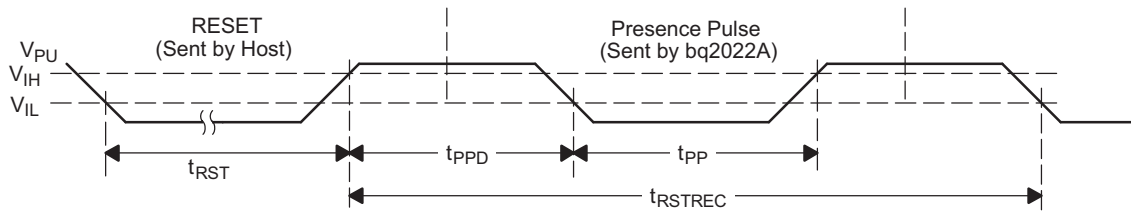

Figure 6. Reset Timing Diagram

8.3.4 WRITE

The WRITE bit timing diagram in [Figure 7](#) shows that the host initiates the transmission by issuing the t_{WSTRB} portion of the bit and then either driving the DATA bus low for a WRITE 0, or releasing the DATA bus for a WRITE 1.

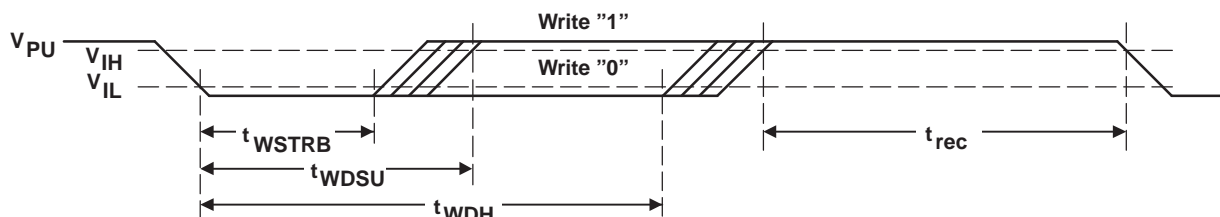

Figure 7. Write Bit Timing Diagram

8.3.5 READ

The READ bit timing diagram in [Figure 8](#) shows that the host initiates the transmission of the bit by issuing the t_{RSTRB} portion of the bit. The bq27320 then responds by either driving the DATA bus low to transmit a READ 0 or releasing the DATA bus to transmit a READ 1.

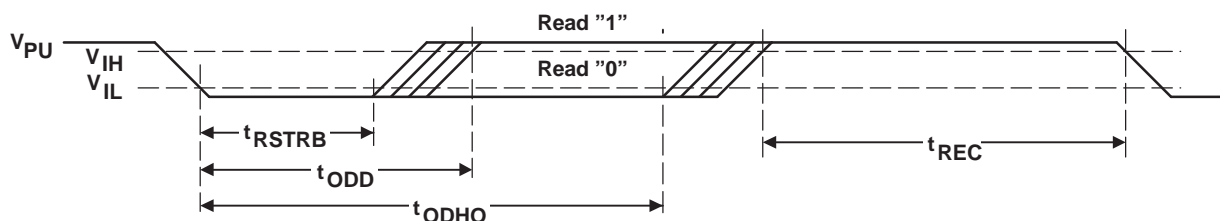

Figure 8. Read Bit Timing Diagram

8.3.6 Program Pulse

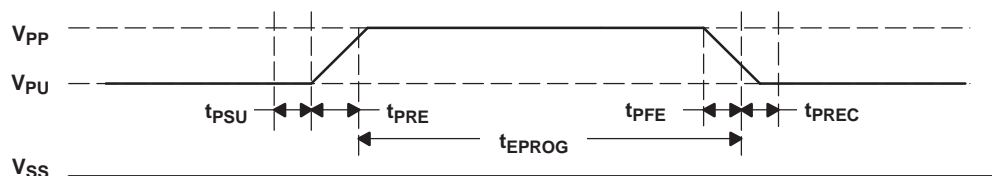

Figure 9. Program Pulse Timing Diagram

8.3.7 IDLE

If the bus is high, the bus is in the IDLE state. Bus transactions can be suspended by leaving the DATA bus in IDLE. Bus transactions can resume at any time from the IDLE state.

8.3.8 CRC Generation

The bq27320 has an 8-bit CRC stored in the most significant byte of the 64-bit ROM. The bus master can compute a CRC value from the first 56 bits of the 64-bit ROM and compare it to the value stored within the bq27320 to determine if the ROM data has been received error-free by the bus master. The equivalent polynomial function of this CRC is: $X^8 + X^5 + X^4 + 1$.

Under certain conditions, the bq27320 also generates an 8-bit CRC value using the same polynomial function shown and provides this value to the bus master to validate the transfer of command, address, and data bytes from the bus master to the bq27320. The bq27320 computes an 8-bit CRC for the command, address, and data bytes received for the WRITE MEMORY and the WRITE STATUS commands and then outputs this value to the bus master to confirm proper transfer. Similarly, the bq27320 computes an 8-bit CRC for the command and address bytes received from the bus master for the READ MEMORY, READ STATUS, and READ DATA/GENERATE 8-BIT CRC commands to confirm that these bytes have been received correctly. The CRC generator on the bq27320 is also used to provide verification of error-free data transfer as each page of data from the 1024-bit EPROM is sent to the bus master during a READ DATA/GENERATE 8-BIT CRC command, and for the eight bytes of information in the status memory field.

In each case where a CRC is used for data transfer validation, the bus master must calculate a CRC value using the polynomial function previously given and compare the calculated value to either the 8-bit CRC value stored in the 64-bit ROM portion of the bq27320 (for ROM reads) or the 8-bit CRC value computed within the bq27320. The comparison of CRC values and decision to continue with an operation are determined entirely by the bus master. No circuitry on the bq27320 prevents a command sequence from proceeding if the CRC stored in or calculated by the bq27320 does not match the value generated by the bus master. Proper use of the CRC can result in a communication channel with a high level of integrity.

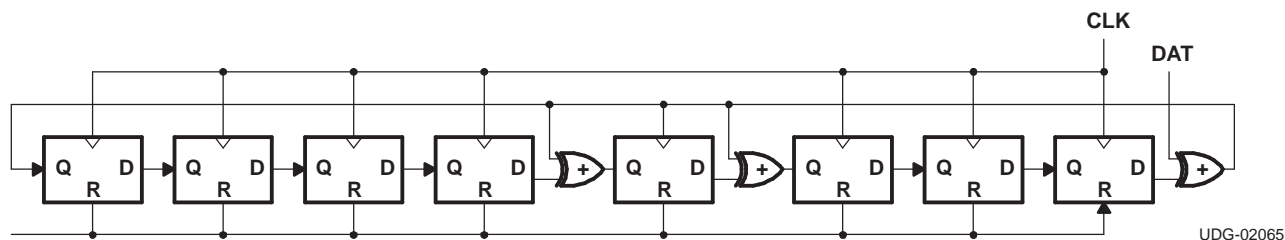
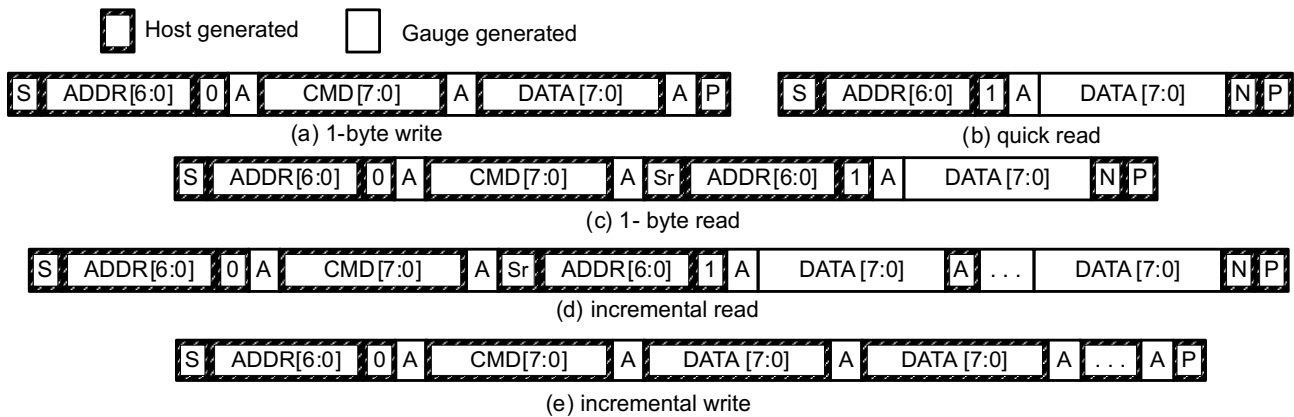

Figure 10. 8-Bit CRC Generator Circuit ($X^8 + X^5 + X^4 + 1$)

8.3.9 Communications

8.3.9.1 I²C Interface

The bq27320 supports the standard I²C read, incremental read, quick read, one-byte write, and incremental write functions. The 7-bit device address (ADDR) is the most significant 7 bits of the hex address and is fixed as 1010101. The first 8 bits of the I²C protocol are, therefore, 0xAA or 0xAB for write or read, respectively.



(S = Start, Sr = Repeated Start, A = Acknowledge, N = No Acknowledge, and P = Stop).

The quick read returns data at the address indicated by the address pointer. The address pointer, a register internal to the I²C communication engine, increments whenever data is acknowledged by the bq27320 or the I²C master. “Quick writes” function in the same manner and are a convenient means of sending multiple bytes to consecutive command locations (such as two-byte commands that require two bytes of data).

The following command sequences are not supported:

Attempt to write a read-only address (NACK after data sent by master):

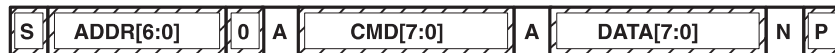

Attempt to read an address above 0x6B (NACK command):



8.3.9.2 I²C Time Out

The I²C engine releases both SDA and SCL if the I²C bus is held low for 2 seconds. If the bq27320 is holding the lines, releasing them frees them for the master to drive the lines. If an external condition is holding either of the lines low, the I²C engine enters the low-power sleep mode.

8.3.9.3 I²C Command Waiting Time

To ensure proper operation at 400 kHz, a $t_{(BUF)} \geq 66 \mu s$ bus-free waiting time must be inserted between all packets addressed to the bq27320. In addition, if the SCL clock frequency (f_{SCL}) is > 100 kHz, use individual 1-byte write commands for proper data flow control. The following diagram shows the standard waiting time required between issuing the control subcommand the reading the status result. For read-write standard command, a minimum of 2 seconds is required to get the result updated. For read-only standard commands, there is no waiting time required, but the host must not issue any standard command more than two times per second. Otherwise, the gauge could result in a reset issue due to the expiration of the watchdog timer.

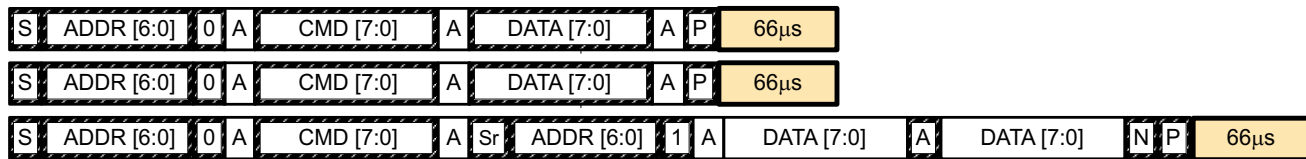

Waiting time inserted between two 1-byte write packets for a subcommand and reading results (required for $100 \text{ kHz} < f_{\text{SCL}} \leq 400 \text{ kHz}$)

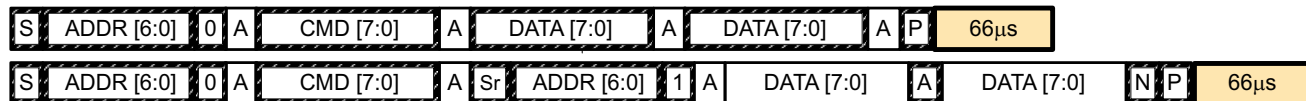

Waiting time inserted between incremental 2-byte write packet for a subcommand and reading results (acceptable for $f_{\text{SCL}} \leq 100 \text{ kHz}$)

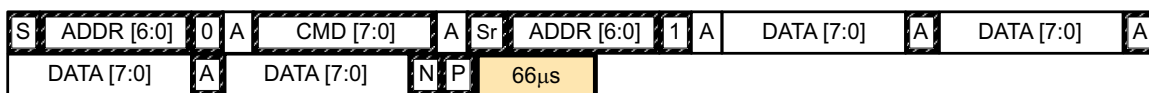

Waiting time inserted after incremental read

8.3.9.4 I²C Clock Stretching

A clock stretch can occur during all modes of fuel gauge operation. In SNOOZE and HIBERNATE modes, a short clock stretch occurs on all I²C traffic as the device must wake-up to process the packet. In the other modes (BAT INSERT CHECK, NORMAL) clock stretching only occurs for packets addressed for the fuel gauge. The majority of clock stretch periods are small as the I²C interface performs normal data flow control. However, less frequent yet more significant clock stretch periods may occur as blocks of data flash are updated. The following table summarizes the approximate clock stretch duration for various fuel gauge operating conditions.

Gauging Mode	Operating Condition/Comment	Approximate Duration
SLEEP HIBERNATE	Clock stretch occurs at the beginning of all traffic as the device wakes up.	≤ 4 ms
BAT INSERT CHECK NORMAL	Clock stretch occurs within the packet for flow control (after a start bit, ACK or first data bit).	≤ 4 ms
	Data flash block writes.	72 ms
	Restored data flash block write after loss of power.	116 ms

8.4 Device Functional Modes

To minimize power consumption, the device has different power modes: NORMAL, SNOOZE, SLEEP, HIBERNATE, and BAT INSERT CHECK. The bq27320 passes automatically between these modes, depending upon the occurrence of specific events, though a system processor can initiate some of these modes directly.

- In NORMAL mode, the gas gauge is fully powered and can execute any allowable task.
- In SNOOZE mode, low-frequency and high-frequency oscillators are active. Although the SNOOZE mode has higher current consumption than the SLEEP mode, it is also a reduced power mode.
- In SLEEP mode, the gas gauge turns off the high-frequency oscillator and exists in a reduced-power state, periodically taking measurements and performing calculations.
- In HIBERNATE mode, the gas gauge is in a low-power state, but can be woken up by communication or certain IO activity.
- BAT INSERT CHECK mode is a powered up, but low-power halted, state, where the gas gauge resides when no battery is inserted into the system.

9 Application and Implementation

NOTE

Information in the following applications sections is not part of the TI component specification, and TI does not warrant its accuracy or completeness. TI's customers are responsible for determining suitability of components for their purposes. Customers should validate and test their design implementation to confirm system functionality.

9.1 Application Information

The bq27320 system-side Li-Ion battery fuel gauge is a microcontroller peripheral that provides fuel gauging for single-cell Li-Ion battery packs. The device requires little system microcontroller firmware development.

The fuel resides on the main board of the system and manages an embedded battery (non-removable) or removable battery pack. To allow for optimal performance in the end application, special considerations must be taken to ensure minimization of measurement error through proper printed circuit board (PCB) board layout.

9.2.1 Design Requirements

Several key parameters must be updated to align with a given application's battery characteristics. For highest accuracy gauging, it is important to follow-up this initial configuration with a learning cycle to optimize resistance and maximum chemical capacity (Qmax) values prior to sealing and shipping systems to the field. Successful and accurate configuration of the fuel gauge for a target application can be used as the basis for creating a "golden" gas gauge (.fs) file that can be written to all gauges, assuming identical pack design and Li-ion cell origin (chemistry, lot, and so on). Calibration data is included as part of this golden GG file to cut down on system production time. If going this route, it is recommended to average the voltage and current measurement calibration data from a large sample size and use these in the golden file. [Table 3, Key Data Flash Parameters for Configuration](#), shows the items that should be configured to achieve reliable protection and accurate gauging with minimal initial configuration.

Table 3. Key Data Flash Parameters for Configuration

NAME	DEFAULT	UNIT	RECOMMENDED SETTING
Design Capacity	1000	mAh	Set based on the nominal pack capacity as interpreted from cell manufacturer's datasheet. If multiple parallel cells are used, should be set to N × Cell Capacity.
Design Energy Scale	1	—	Set to 10 to convert all power values to cWh or to 1 for mWh. Design Energy is divided by this value.
Reserve Capacity-mAh	0	mAh	Set to desired runtime remaining (in seconds / 3600) × typical applied load between reporting 0% SOC and reaching Terminate Voltage , if needed.
Chem ID	0100	hex	Should be configured using TI-supplied Battery Management Studio software. Default open-circuit voltage and resistance tables are also updated in conjunction with this step. Do not attempt to manually update reported Device Chemistry as this does not change all chemistry information! Always update chemistry using the appropriate software tool (that is, bqStudio).
Load Mode	1	—	Set to applicable load model, 0 for constant current or 1 for constant power.
Load Select	1	—	Set to load profile which most closely matches typical system load.
Qmax Cell 0	1000	mAh	Set to initial configured value for Design Capacity. The gauge will update this parameter automatically after the optimization cycle and for every regular Qmax update thereafter.
Cell0 V at Chg Term	4200	mV	Set to nominal cell voltage for a fully charged cell. The gauge will update this parameter automatically each time full charge termination is detected.
Terminate Voltage	3200	mV	Set to empty point reference of battery based on system needs. Typical is between 3000 and 3200 mV.
Ra Max Delta	44	mΩ	Set to 15% of Cell0 R _a 4 resistance after an optimization cycle is completed.
Charging Voltage	4200	mV	Set based on nominal charge voltage for the battery in normal conditions (25°C, etc). Used as the reference point for offsetting by Taper Voltage for full charge termination detection.
Taper Current	100	mA	Set to the nominal taper current of the charger + taper current tolerance to ensure that the gauge will reliably detect charge termination.
Taper Voltage	100	mV	Sets the voltage window for qualifying full charge termination. Can be set tighter to avoid or wider to ensure possibility of reporting 100% SOC in outer JEITA temperature ranges that use derated charging voltage.
Dsg Current Threshold	60	mA	Sets threshold for gauge detecting battery discharge. Should be set lower than minimal system load expected in the application and higher than Quit Current .
Chg Current Threshold	75	mA	Sets the threshold for detecting battery charge. Can be set higher or lower depending on typical trickle charge current used. Also should be set higher than Quit Current .
Quit Current	40	mA	Sets threshold for gauge detecting battery relaxation. Can be set higher or lower depending on typical standby current and exhibited in the end system.
Avg I Last Run	-299	mA	Current profile used in capacity simulations at onset of discharge or at all times if Load Select = 0. Should be set to nominal system load. Is automatically updated by the gauge every cycle.
Avg P Last Run	-1131	mW	Power profile used in capacity simulations at onset of discharge or at all times if Load Select = 0. Should be set to nominal system power. Is automatically updated by the gauge every cycle.
Sleep Current	15	mA	Sets the threshold at which the fuel gauge enters SLEEP mode. Take care in setting above typical standby currents else entry to SLEEP may be unintentionally blocked.

Table 3. Key Data Flash Parameters for Configuration (continued)

NAME	DEFAULT	UNIT	RECOMMENDED SETTING
CC Gain	10	mΩ	Calibrate this parameter using TI-supplied bqStudio software and calibration procedure in the TRM. Determines conversion of coulomb counter measured sense resistor voltage to current.
CC Delta	10	mΩ	Calibrate this parameter using TI-supplied bqStudio software and calibration procedure in the TRM. Determines conversion of coulomb counter measured sense resistor voltage to passed charge.
CC Offset	-1418	Counts	Calibrate this parameter using TI-supplied bqStudio software and calibration procedure in the TRM. Determines native offset of coulomb counter hardware that should be removed from conversions.
Board Offset	0	Counts	Calibrate this parameter using TI-supplied bqStudio software and calibration procedure in the TRM. Determines native offset of the printed circuit board parasitics that should be removed from conversions.
Pack V Offset	0	mV	Calibrate this parameter using TI-supplied bqStudio software and calibration procedure in the TRM. Determines voltage offset between cell tab and ADC input node to incorporate back into or remove from measurement, depending on polarity.

9.2.2 Detailed Design Procedure

9.2.2.1 BAT Voltage Sense Input

A ceramic capacitor at the input to the BAT pin is used to bypass AC voltage ripple to ground, greatly reducing its influence on battery voltage measurements. It proves most effective in applications with load profiles that exhibit high-frequency current pulses (that is, cell phones) but is recommended for use in all applications to reduce noise on this sensitive high-impedance measurement node.

9.2.2.2 SRP and SRN Current Sense Inputs

The filter network at the input to the coulomb counter is intended to improve differential mode rejection of voltage measured across the sense resistor. These components should be placed as close as possible to the coulomb counter inputs and the routing of the differential traces length-matched to best minimize impedance mismatch-induced measurement errors.

9.2.2.3 Sense Resistor Selection

Any variation encountered in the resistance present between the SRP and SRN pins of the fuel gauge will affect the resulting differential voltage, and derived current, it senses. As such, it is recommended to select a sense resistor with minimal tolerance and temperature coefficient of resistance (TCR) characteristics. The standard recommendation based on best compromise between performance and price is a 1% tolerance, 100-ppm drift sense resistor with a 1-W power rating.

9.2.2.4 TS Temperature Sense Input

Similar to the BAT pin, a ceramic decoupling capacitor for the TS pin is used to bypass AC voltage ripple away from the high-impedance ADC input, minimizing measurement error. Another helpful advantage is that the capacitor provides additional ESD protection since the TS input to system may be accessible in systems that use removable battery packs. It should be placed as close as possible to the respective input pin for optimal filtering performance.

9.2.2.5 Thermistor Selection

The fuel gauge temperature sensing circuitry is designed to work with a negative temperature coefficient-type (NTC) thermistor with a characteristic 10-kΩ resistance at room temperature (25°C). The default curve-fitting coefficients configured in the fuel gauge specifically assume a 103AT-2 type thermistor profile and so that is the default recommendation for thermistor selection purposes. Moving to a separate thermistor resistance profile (for example, JT-2 or others) requires an update to the default thermistor coefficients in data flash to ensure highest accuracy temperature measurement performance.

9.2.2.6 REGIN Power Supply Input Filtering

A ceramic capacitor is placed at the input to the fuel gauge internal LDO to increase power supply rejection (PSR) and improve effective line regulation. It ensures that voltage ripple is rejected to ground instead of coupling into the internal supply rails of the fuel gauge.

9.2.2.7 V_{CC} LDO Output Filtering

A ceramic capacitor is also needed at the output of the internal LDO to provide a current reservoir for fuel gauge load peaks during high peripheral utilization. It acts to stabilize the regulator output and reduce core voltage ripple inside of the fuel gauge.

9.2.3 Application Curves

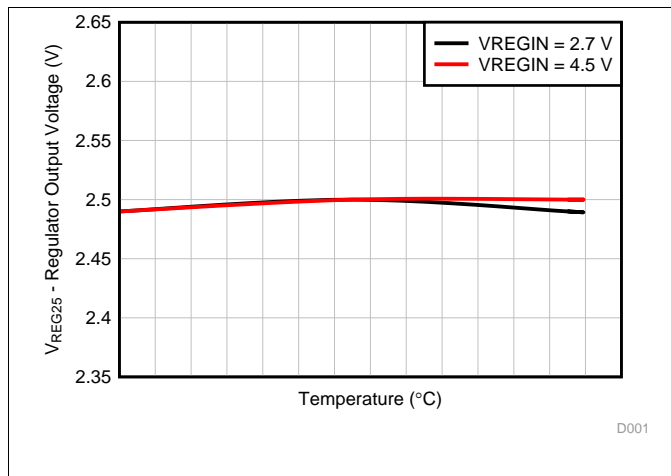

Figure 12. Regulator Output Voltage vs. Temperature

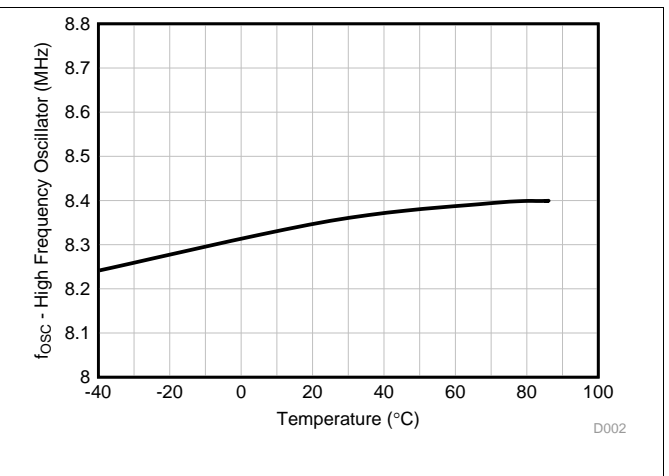

Figure 13. High-Frequency Oscillator Frequency vs. Temperature

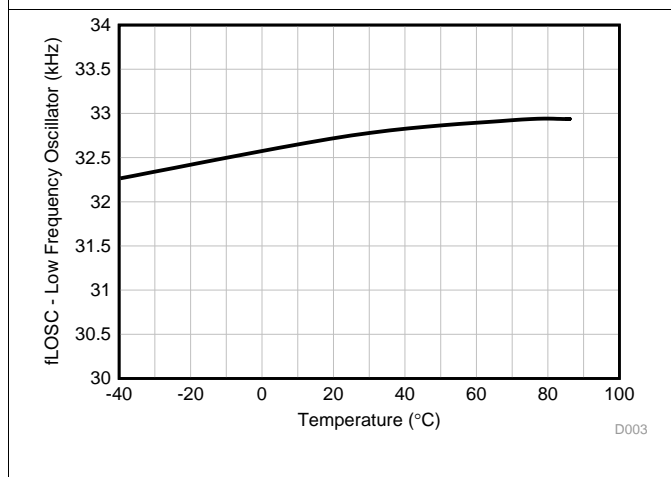

Figure 14. Low-Frequency Oscillator Frequency vs. Temperature

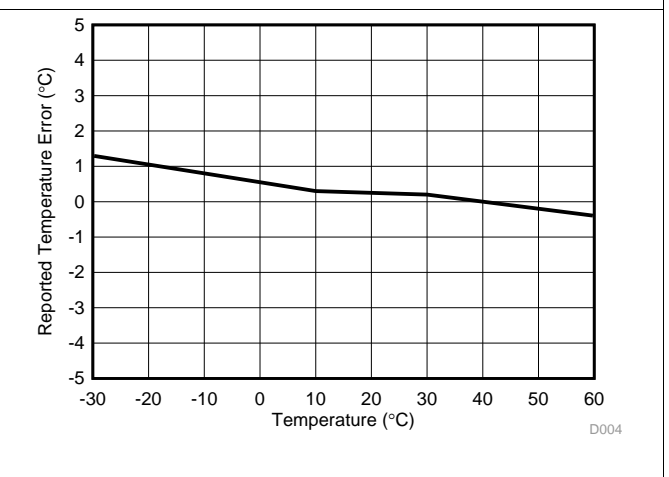

Figure 15. Reported Internal Temperature Measurement vs. Temperature

10 Power Supply Recommendations

10.1 Power Supply Decoupling

Both the REGIN input pin and the V_{CC} output pin require low equivalent series resistance (ESR) ceramic capacitors placed as closely as possible to the respective pins to optimize ripple rejection and provide a stable and dependable power rail that is resilient to line transients. A 0.1- μF capacitor at the REGIN and a 1- μF capacitor at V_{CC} will suffice for satisfactory device performance.

11 Layout

11.1 Layout Guidelines

11.1.1 Sense Resistor Connections

Kelvin connections at the sense resistor are just as critical as those for the battery terminals themselves. The differential traces should be connected at the inside of the sense resistor pads and not anywhere along the high-current trace path to prevent false increases to measured current that could result when measuring between the sum of the sense resistor and trace resistance between the tap points. In addition, the routing of these leads from the sense resistor to the input filter network and finally into the SRP and SRN pins needs to be as closely matched in length as possible else additional measurement offset could occur. It is further recommended to add copper trace or pour-based "guard rings" around the perimeter of the filter network and coulomb counter inputs to shield these sensitive pins from radiated EMI into the sense nodes. This prevents differential voltage shifts that could be interpreted as real current change to the fuel gauge. All of the filter components need to be placed as close as possible to the coulomb counter input pins.

11.1.2 Thermistor Connections

The thermistor sense input should include a ceramic bypass capacitor placed as close to the TS input pin as possible. The capacitor helps to filter measurements of any stray transients as the voltage bias circuit pulses periodically during temperature sensing windows.

11.1.3 High-Current and Low-Current Path Separation

For best possible noise performance, it is extremely important to separate the low-current and high-current loops to different areas of the board layout. The fuel gauge and all support components should be situated on one side of the boards and tap off of the high-current loop (for measurement purposes) at the sense resistor. Routing the low-current ground around instead of under high-current traces will further help to improve noise rejection.

11.2 Layout Example

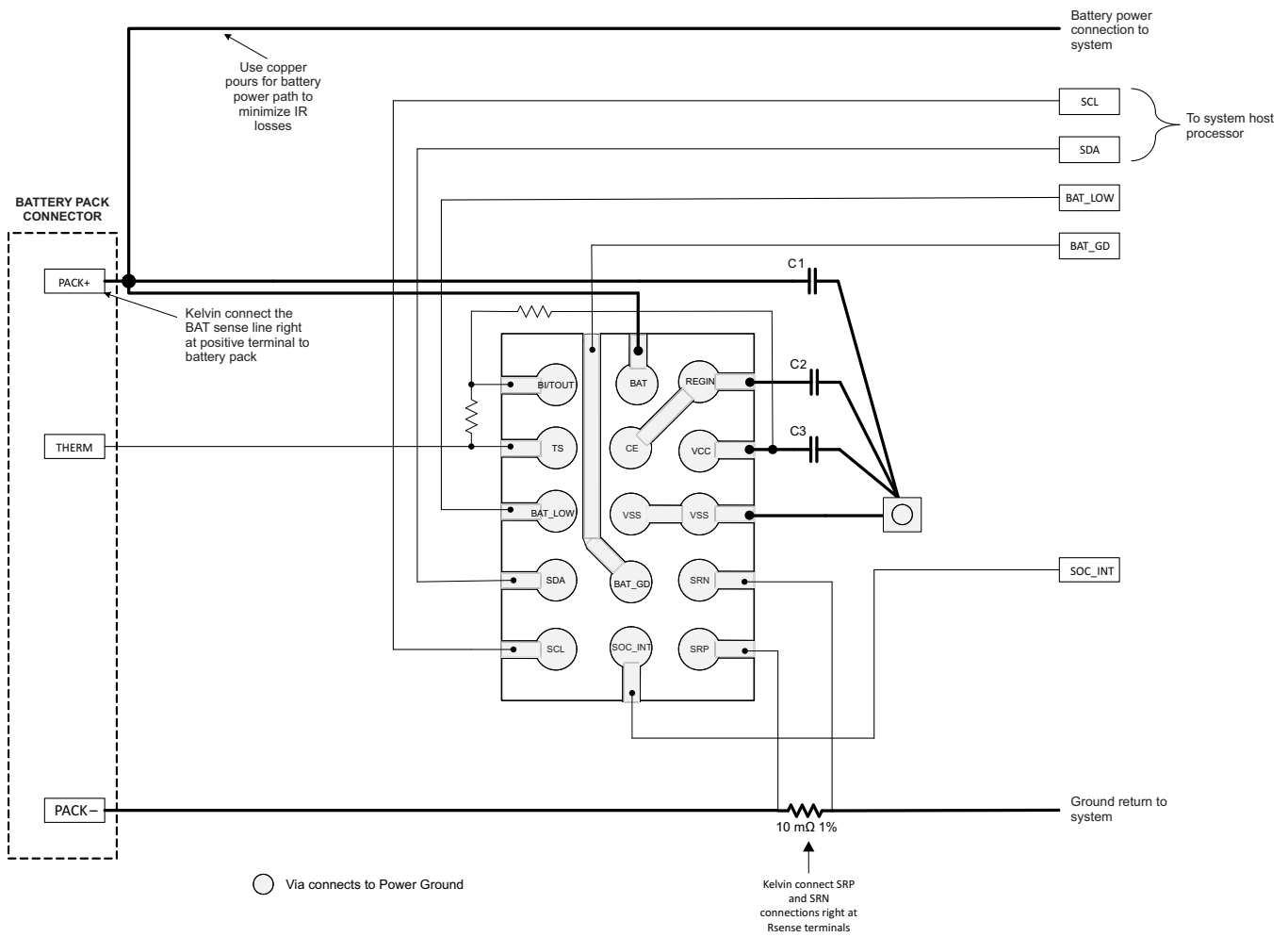

Figure 16. Layout Recommendation

12 Device and Documentation Support

12.1 Documentation Support

12.1.1 Related Documentation

For related documentation, see the following: *bq27320 Technical Reference Manual* ([SLUUBE6](#)).

12.2 Community Resources

The following links connect to TI community resources. Linked contents are provided "AS IS" by the respective contributors. They do not constitute TI specifications and do not necessarily reflect TI's views; see TI's [Terms of Use](#).

TI E2E™ Online Community *TI's Engineer-to-Engineer (E2E) Community*. Created to foster collaboration among engineers. At [e2e.ti.com](#), you can ask questions, share knowledge, explore ideas and help solve problems with fellow engineers.

Design Support *TI's Design Support* Quickly find helpful E2E forums along with design support tools and contact information for technical support.

12.3 Trademarks

NanoFree, E2E are trademarks of Texas Instruments.
I²C is a trademark of NXP Semiconductors.

12.4 Electrostatic Discharge Caution



This integrated circuit can be damaged by ESD. Texas Instruments recommends that all integrated circuits be handled with appropriate precautions. Failure to observe proper handling and installation procedures can cause damage.

ESD damage can range from subtle performance degradation to complete device failure. Precision integrated circuits may be more susceptible to damage because very small parametric changes could cause the device not to meet its published specifications.

12.5 Glossary

[SLYZ022](#) — *TI Glossary*.

This glossary lists and explains terms, acronyms, and definitions.

13 Mechanical, Packaging, and Orderable Information

The following pages include mechanical, packaging, and orderable information. This information is the most current data available for the designated devices. This data is subject to change without notice and revision of this document. For browser-based versions of this data sheet, refer to the left-hand navigation.

PACKAGING INFORMATION

Orderable Device	Status (1)	Package Type	Package Drawing	Pins	Package Qty	Eco Plan (2)	Lead/Ball Finish (6)	MSL Peak Temp (3)	Op Temp (°C)	Device Marking (4/5)	Samples
BQ27320YZFR	PREVIEW	DSBGA	YZF	15	3000	Green (RoHS & no Sb/Br)	SNAGCU	Level-1-260C-UNLIM	-40 to 85	BQ27320	
BQ27320YZFT	PREVIEW	DSBGA	YZF	15	250	Green (RoHS & no Sb/Br)	SNAGCU	Level-1-260C-UNLIM	-40 to 85	BQ27320	

(1) The marketing status values are defined as follows:

ACTIVE: Product device recommended for new designs.

LIFEBUY: TI has announced that the device will be discontinued, and a lifetime-buy period is in effect.

NRND: Not recommended for new designs. Device is in production to support existing customers, but TI does not recommend using this part in a new design.

PREVIEW: Device has been announced but is not in production. Samples may or may not be available.

OBSELETE: TI has discontinued the production of the device.

(2) Eco Plan - The planned eco-friendly classification: Pb-Free (RoHS), Pb-Free (RoHS Exempt), or Green (RoHS & no Sb/Br) - please check <http://www.ti.com/productcontent> for the latest availability information and additional product content details.

TBD: The Pb-Free/Green conversion plan has not been defined.

Pb-Free (RoHS): TI's terms "Lead-Free" or "Pb-Free" mean semiconductor products that are compatible with the current RoHS requirements for all 6 substances, including the requirement that lead not exceed 0.1% by weight in homogeneous materials. Where designed to be soldered at high temperatures, TI Pb-Free products are suitable for use in specified lead-free processes.

Pb-Free (RoHS Exempt): This component has a RoHS exemption for either 1) lead-based flip-chip solder bumps used between the die and package, or 2) lead-based die adhesive used between the die and leadframe. The component is otherwise considered Pb-Free (RoHS compatible) as defined above.

Green (RoHS & no Sb/Br): TI defines "Green" to mean Pb-Free (RoHS compatible), and free of Bromine (Br) and Antimony (Sb) based flame retardants (Br or Sb do not exceed 0.1% by weight in homogeneous material)

(3) MSL, Peak Temp. - The Moisture Sensitivity Level rating according to the JEDEC industry standard classifications, and peak solder temperature.

(4) There may be additional marking, which relates to the logo, the lot trace code information, or the environmental category on the device.

(5) Multiple Device Markings will be inside parentheses. Only one Device Marking contained in parentheses and separated by a "~" will appear on a device. If a line is indented then it is a continuation of the previous line and the two combined represent the entire Device Marking for that device.

(6) Lead/Ball Finish - Orderable Devices may have multiple material finish options. Finish options are separated by a vertical ruled line. Lead/Ball Finish values may wrap to two lines if the finish value exceeds the maximum column width.

Important Information and Disclaimer:The information provided on this page represents TI's knowledge and belief as of the date that it is provided. TI bases its knowledge and belief on information provided by third parties, and makes no representation or warranty as to the accuracy of such information. Efforts are underway to better integrate information from third parties. TI has taken and continues to take reasonable steps to provide representative and accurate information but may not have conducted destructive testing or chemical analysis on incoming materials and chemicals. TI and TI suppliers consider certain information to be proprietary, and thus CAS numbers and other limited information may not be available for release.

In no event shall TI's liability arising out of such information exceed the total purchase price of the TI part(s) at issue in this document sold by TI to Customer on an annual basis.

YZF (R-XBGA-N15)

DIE-SIZE BALL GRID ARRAY

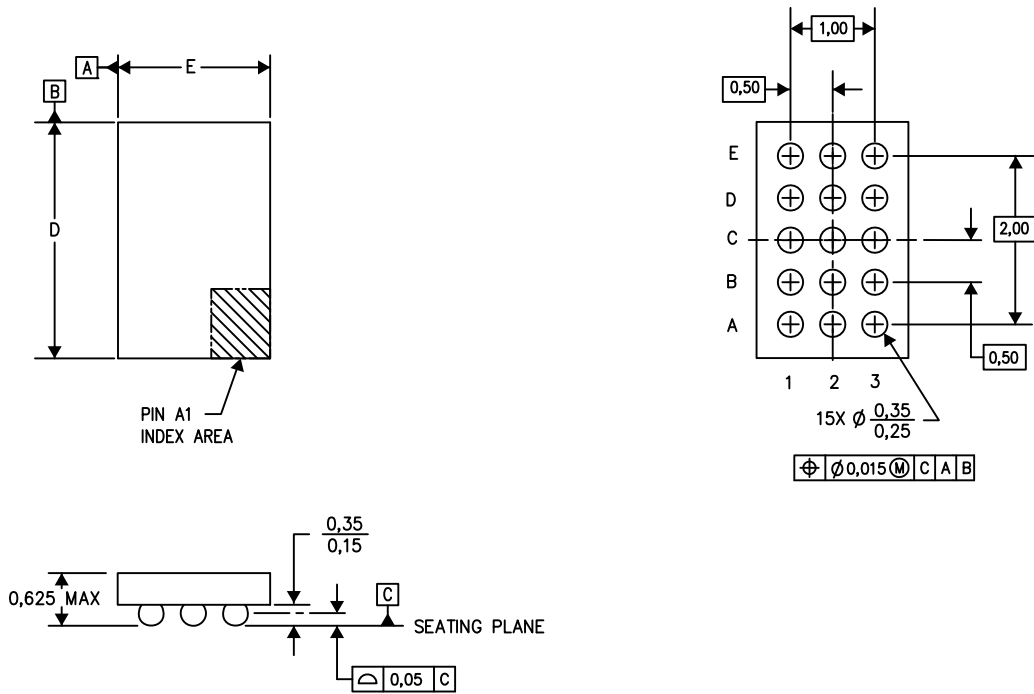

D: Max = 2.64 mm, Min = 2.58 mm
 E: Max = 1.986 mm, Min = 1.926 mm

4205058-5/P 07/13

- NOTES: A. All linear dimensions are in millimeters. Dimensioning and tolerancing per ASME Y14.5M-1994.
 B. This drawing is subject to change without notice.
 C. NanoFree™ package configuration.

NanoFree is a trademark of Texas Instruments.

IMPORTANT NOTICE

Texas Instruments Incorporated and its subsidiaries (TI) reserve the right to make corrections, enhancements, improvements and other changes to its semiconductor products and services per JESD46, latest issue, and to discontinue any product or service per JESD48, latest issue. Buyers should obtain the latest relevant information before placing orders and should verify that such information is current and complete. All semiconductor products (also referred to herein as "components") are sold subject to TI's terms and conditions of sale supplied at the time of order acknowledgment.

TI warrants performance of its components to the specifications applicable at the time of sale, in accordance with the warranty in TI's terms and conditions of sale of semiconductor products. Testing and other quality control techniques are used to the extent TI deems necessary to support this warranty. Except where mandated by applicable law, testing of all parameters of each component is not necessarily performed.

TI assumes no liability for applications assistance or the design of Buyers' products. Buyers are responsible for their products and applications using TI components. To minimize the risks associated with Buyers' products and applications, Buyers should provide adequate design and operating safeguards.

TI does not warrant or represent that any license, either express or implied, is granted under any patent right, copyright, mask work right, or other intellectual property right relating to any combination, machine, or process in which TI components or services are used. Information published by TI regarding third-party products or services does not constitute a license to use such products or services or a warranty or endorsement thereof. Use of such information may require a license from a third party under the patents or other intellectual property of the third party, or a license from TI under the patents or other intellectual property of TI.

Reproduction of significant portions of TI information in TI data books or data sheets is permissible only if reproduction is without alteration and is accompanied by all associated warranties, conditions, limitations, and notices. TI is not responsible or liable for such altered documentation. Information of third parties may be subject to additional restrictions.

Resale of TI components or services with statements different from or beyond the parameters stated by TI for that component or service voids all express and any implied warranties for the associated TI component or service and is an unfair and deceptive business practice. TI is not responsible or liable for any such statements.

Buyer acknowledges and agrees that it is solely responsible for compliance with all legal, regulatory and safety-related requirements concerning its products, and any use of TI components in its applications, notwithstanding any applications-related information or support that may be provided by TI. Buyer represents and agrees that it has all the necessary expertise to create and implement safeguards which anticipate dangerous consequences of failures, monitor failures and their consequences, lessen the likelihood of failures that might cause harm and take appropriate remedial actions. Buyer will fully indemnify TI and its representatives against any damages arising out of the use of any TI components in safety-critical applications.

In some cases, TI components may be promoted specifically to facilitate safety-related applications. With such components, TI's goal is to help enable customers to design and create their own end-product solutions that meet applicable functional safety standards and requirements. Nonetheless, such components are subject to these terms.

No TI components are authorized for use in FDA Class III (or similar life-critical medical equipment) unless authorized officers of the parties have executed a special agreement specifically governing such use.

Only those TI components which TI has specifically designated as military grade or "enhanced plastic" are designed and intended for use in military/aerospace applications or environments. Buyer acknowledges and agrees that any military or aerospace use of TI components which have **not** been so designated is solely at the Buyer's risk, and that Buyer is solely responsible for compliance with all legal and regulatory requirements in connection with such use.

TI has specifically designated certain components as meeting ISO/TS16949 requirements, mainly for automotive use. In any case of use of non-designated products, TI will not be responsible for any failure to meet ISO/TS16949.

Products

Audio	www.ti.com/audio
Amplifiers	amplifier.ti.com
Data Converters	dataconverter.ti.com
DLP® Products	www.dlp.com
DSP	dsp.ti.com
Clocks and Timers	www.ti.com/clocks
Interface	interface.ti.com
Logic	logic.ti.com
Power Mgmt	power.ti.com
Microcontrollers	microcontroller.ti.com
RFID	www.ti-rfid.com
OMAP Applications Processors	www.ti.com/omap
Wireless Connectivity	www.ti.com/wirelessconnectivity

Applications

Automotive and Transportation	www.ti.com/automotive
Communications and Telecom	www.ti.com/communications
Computers and Peripherals	www.ti.com/computers
Consumer Electronics	www.ti.com/consumer-apps
Energy and Lighting	www.ti.com/energy
Industrial	www.ti.com/industrial
Medical	www.ti.com/medical
Security	www.ti.com/security
Space, Avionics and Defense	www.ti.com/space-avionics-defense
Video and Imaging	www.ti.com/video

TI E2E Community

e2e.ti.com