

DESCRIPTION

The MP3388 is a step-up converter with 8-channel current sources designed for driving the white LED arrays for large size LCD panel backlighting applications.

The MP3388 uses current mode, fixed frequency architecture. The switching frequency can be selected at 1.25MHz or 625kHz. It generates an output voltage up to 50V from a 4.5V to 25V input supply. The MP3388 independently regulates the current in each LED string to the user programmed value set by an external current setting resistor.

The MP3388 applies 8 internal current sources in each LED string terminal to achieve a current balance of 3% regulation accuracy between strings. Its low 600mV regulation voltage on LED current sources reduces power loss and improves efficiency.

The MP3388 features external PWM dimming or DC input PWM dimming, which allows the flexible control of the backlighting luminance. The dimming PWM signal can be generated internally, and the dimming frequency is programmed by an external setting capacitor.

FEATURES

- High Efficiency and Small Size
- 4.5V to 25V Input Voltage Range
- 50V Maximum Step-up Voltage
- Balanced Driver for 8 Strings of WLED
- 3% Current Matching Accuracy Between Strings
- Selectable Switching Frequency: 1.25MHz or 625kHz
- PWM or DC Input Burst PWM Dimming
- Programmable Over-voltage Protection
- Under Voltage Lockout
- Open and Short LED protection
- Thermal Shutdown
- Small QFN24 (4x4mm) and 28 pin SOIC packages
- Halogens Free

APPLICATIONS

- Notebook PC
- Small LCD TV
- Handy Terminals Display
- Automotive System and Tablet Computer

All MPS parts are lead-free and adhere to the RoHS directive. For MPS green status, please visit MPS website under Quality Assurance. "MPS" and "The Future of Analog IC Technology" are Registered Trademarks of Monolithic Power Systems, Inc.

TYPICAL APPLICATION

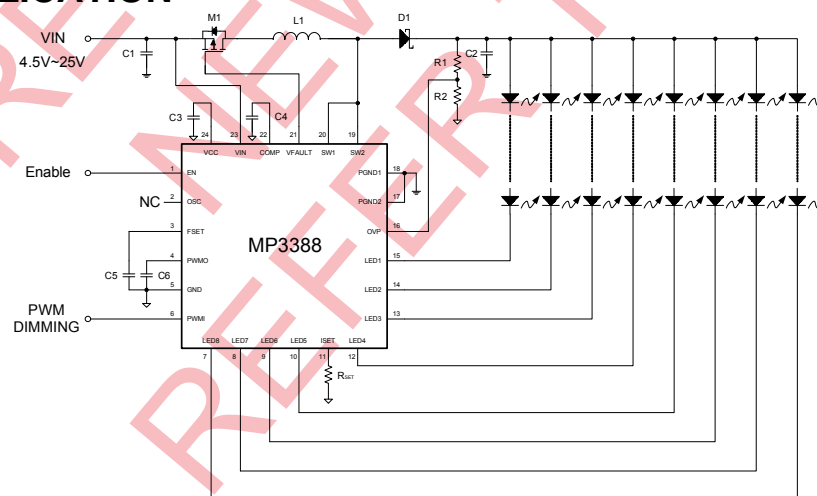

ORDERING INFORMATION

Part Number	Package	Top Marking	Free Air Temperature (T _A)
MP3388DR*	QFN24 (4x4mm)	3388DR	-40°C TO +85°C
MP3388EY	SOIC28	MP3388EY	-20°C TO +85°C

* For Tape & Reel, add suffix -Z (e.g. MP3388DR-Z).

For RoHS Compliant Packaging, add suffix -LF (e.g. MP3388DR-LF-Z)

PACKAGE REFERENCE

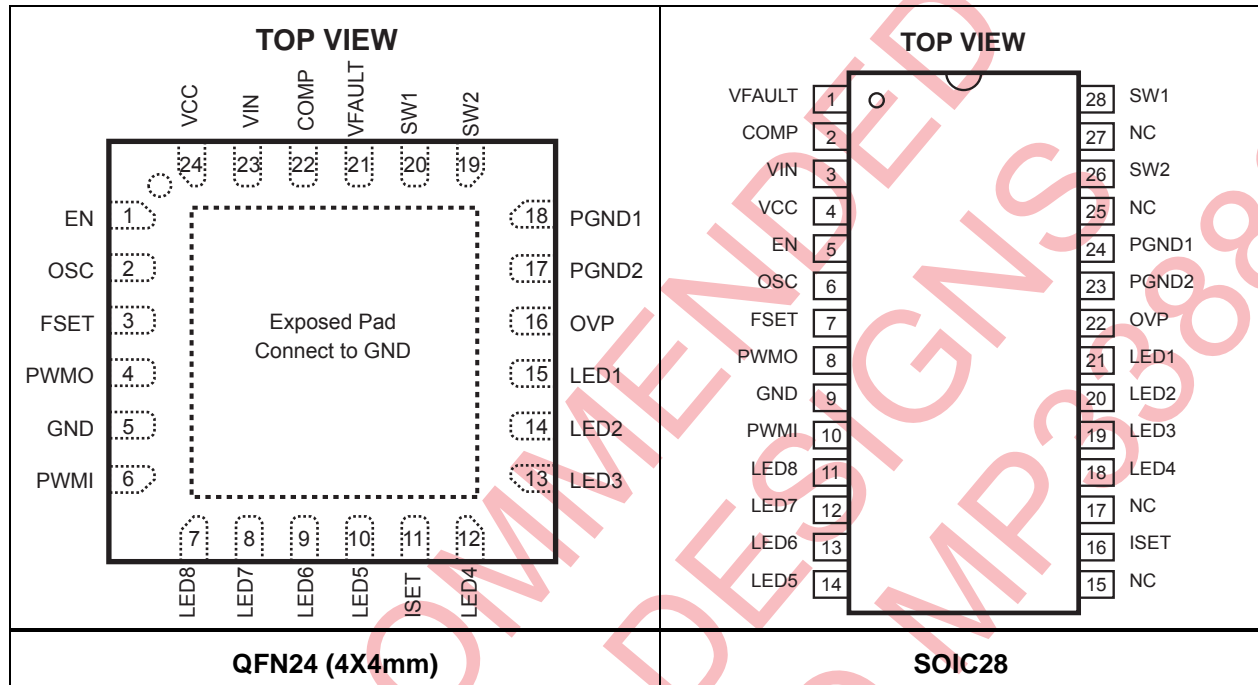

ABSOLUTE MAXIMUM RATINGS ⁽¹⁾

V _{IN}	-0.3V to +30V
V _{VFAULT}	V _{IN} - 6V to V _{IN}
V _{SW}	-0.3V to +50V
V _{LED1} to V _{LED8}	-0.3V to +50V
All Other Pins	-0.3V to +6V
Continuous Power Dissipation (T _A = +25°C) ⁽²⁾	
QFN24 (4x4mm)	2.9W
SOIC28	2.1W
Junction Temperature	150°C
Lead Temperature	260°C
Storage Temperature	-65°C to +150°C

Recommended Operating Conditions ⁽³⁾

Supply Voltage V _{IN}	4.5V to 25V
Maximum Junction Temp. (T _J)	125°C

Thermal Resistance ⁽⁴⁾ θ_{JA} θ_{JC}

QFN24 (4x4mm)	42	9	°C/W
SOIC28	60	30	°C/W

Notes:

- 1) Exceeding these ratings may damage the device.
- 2) The maximum allowable power dissipation is a function of the maximum junction temperature T_{J(MAX)}, the junction-to-ambient thermal resistance θ_{JA}, and the ambient temperature T_A. The maximum allowable continuous power dissipation at any ambient temperature is calculated by P_{D(MAX)} = (T_{J(MAX)} - T_A) / θ_{JA}. Exceeding the maximum allowable power dissipation will cause excessive die temperature, and the regulator will go into thermal shutdown. Internal thermal shutdown circuitry protects the device from permanent damage.
- 3) The device is not guaranteed to function outside of its operation conditions.
- 4) Measured on JESD51-7, 4-layer PCB.

ELECTRICAL CHARACTERISTICS $V_{IN} = 12V$, $V_{EN} = 5V$, $T_A = +25^\circ C$, unless otherwise noted.

Parameters	Symbol	Condition	Min	Typ	Max	Units
Operating Input Voltage	V_{IN}		4.5		25	V
Supply Current (Quiescent)	I_Q	$V_{IN}=12V$, $V_{EN}=5V$, no load.		1.8		mA
Supply Current (Shutdown)	I_{ST}	$V_{EN}=0V$, $V_{IN}=12V$			2	μA
LDO Output Voltage	V_{CC}	$V_{EN}=5V$, $6V < V_{IN} < 25V$, $0 < I_{VCC} < 10mA$	4.5	5	5.5	V
Input UVLO Threshold	V_{IN_UVLO}	Rising Edge	3.4	3.9	4.3	V
Input UVLO Hysteresis				200		mV
EN ON Threshold	V_{EN_ON}	V_{EN} Rising	1.8			V
EN OFF Threshold	V_{EN_OFF}	V_{EN} Falling			0.6	V
STEP-UP CONVERTER						
SW On-Resistance	R_{DS_ON}	$I_{DS}=20mA$		0.18	0.3	Ω
SW Leakage Current	I_{SW_LK}	$V_{SW}=45V$			1	μA
Switching Frequency	f_{SW}	$V_{OSC}=V_{CC}$ or Floating	1.0	1.25	1.5	MHz
		$V_{OSC}=0V$	500	625	750	kHz
OSC High-Level Threshold	V_{OSC_H}		2.1			V
OSC Low-Level Threshold	V_{OSC_L}				0.8	V
Minimum On Time	T_{ON_MIN}	PWM Mode, when no pulse skipping happens		100		ns
Maximum Duty Cycle	D_{MAX}		90	93	96	%
SW Current Limit	I_{SW_LIMIT}	Duty=90%	2.0			A
COMP Transconductance	G_{COMP}	$\Delta I_{COMP}=\pm 10\mu A$		100		$\mu A/V$
COMP Output Current	I_{COMP}			60		μA
PWM DIMMING						
PWMI High-Level Threshold	V_{PWMI_H}		1.5			V
PWMI Low-Level Threshold	V_{PWMI_L}				0.8	V
PWMO Output Impedance	R_{PWMO}		300	400	500	k Ω
PWMI Leakage Current	I_{PWMI_LK}		-1		+1	μA
DPWM Frequency	f_{DPWM}	$C_{FSET}=2.2nF$	1.2	1.6	2	kHz

ELECTRICAL CHARACTERISTICS (continued) $V_{IN} = 12V$, $V_{EN} = 5V$, $T_A = +25^\circ C$, unless otherwise noted.

Parameters	Symbol	Condition	Min	Typ	Max	Units
LED CURRENT REGULATION						
LEDX Average Current	I_{LED}	$R_{ISET}=60.4k\Omega$	19.2	19.9	20.6	mA
Current Matching ⁽⁵⁾		$I_{LED}=20mA$			3	%
Maximum LED Current per String	I_{LEDmax}	$R_{ISET}=40.2 k\Omega$		30		mA
LEDX Regulation Voltage	V_{LEDX}	$I_{LED}=20mA$		600		mV
PROTECTION						
OVP Over Voltage Threshold	V_{OVP_OV}	Rising Edge	1.17	1.23	1.3	V
OVP UVLO threshold	V_{OVP_UV}	Step-up Converter Fails	48	70	102	mV
LEDX Over Voltage Threshold	V_{LEDX_OV}	$V_{IN}>5.5V$	5.1	5.5	5.9	V
LEDX UVLO Threshold	V_{LEDX_UV}		130	175	230	mV
Thermal Shutdown Threshold	T_{ST}			150		$^\circ C$
LEDX Over Voltage Fault Timer			1.3	1.6	1.9	ms
VFAULT Pull Down Current	I_{FAULT}		40	55	70	μA
VFAULT Blocking-Off Voltage (with Respect to V_{IN})	V_{FAULT}	$V_{IN} = 12V$, $V_{IN}-V_{FAULT}$		6		V

Notes:

5) Matching is defined as the difference of the maximum to minimum current divided by 2 times average currents.

PIN FUNCTIONS

QFN24	SOIC28	Name	Description
1	5	EN	Enable Control Input. Do not let this pin floating.
2	6	OSC	Switching Frequency Selection Input. When float this pin or connect this pin to VCC, the step-up converter switching frequency is 1.25MHz. When connect this pin to GND, the step-up converter switching frequency is 625kHz.
3	7	FSET	Dimming PWM Frequency Setting. Connect a capacitor between FSET and GND to set the DPWM frequency by the equation: $f_{DPWM} = 3.5\mu F / C_{FSET}$.
4	8	PWMO	PWM Filter Output. To use external PWM dimming mode, connect a capacitor between PWMO and GND to form a low-pass filter with an internal 400kΩ resistor. It filters the external PWM logic signal on PWMI pin into a DC signal whose level is inversely proportional to the duty-cycle of the input PWM signal. Then the DC signal is converted to a DPWM dimming signal with the same duty-cycle as the external PWM signal. To use DC input PWM dimming mode, directly apply a DC voltage from 0.2V to 1.2V on PWMO pin for dimming PWM duty cycle control. The DC input PWM dimming polarity is negative.
5	9	GND	Analog Ground.
6	10	PWMI	PWM Signal Input. To use the external PWM dimming mode, apply a PWM signal on this pin for brightness control. This signal is filtered and its duty cycle is converted into a DC signal to calculate the DPWM duty cycle. And the DPWM duty cycle equals to the input PWM duty cycle. To use DC input PWM dimming mode, float this pin.
7	11	LED8	LED String 8 Current Input. This pin is the open-drain output of an internal dimming control switch. Connect the LED String 8 cathode to this pin. If this string is not used, connect Vout to this pin.
8	12	LED7	LED String 7 Current Input. This pin is the open-drain output of an internal dimming control switch. Connect the LED String 7 cathode to this pin. If this string is not used, connect Vout to this pin.
9	13	LED6	LED String 6 Current Input. This pin is the open-drain output of an internal dimming control switch. Connect the LED String 6 cathode to this pin. If this string is not used, connect Vout to this pin.
10	14	LED5	LED String 5 Current Input. This pin is the open-drain output of an internal dimming control switch. Connect the LED String 8 cathode to this pin. If this string is not used, connect Vout to this pin.
11	16	ISET	LED Current Setting. Tie a current setting resistor from this pin to ground to program the current in each LED string. $I_{LED} = 1000 \times 1.22V / (R_{SET} + 1k\Omega)$
12	18	LED4	LED String 4 Current Input. This pin is the open-drain output of an internal dimming control switch. Connect the LED String 4 cathode to this pin. If this string is not used, connect Vout to this pin.
13	19	LED3	LED String 3 Current Input. This pin is the open-drain output of an internal dimming control switch. Connect the LED String 3 cathode to this pin. If this string is not used, connect Vout to this pin.
14	20	LED2	LED String 2 Current Input. This pin is the open-drain output of an internal dimming control switch. Connect the LED String 2 cathode to this pin. If this string is not used, connect Vout to this pin.

PIN FUNCTIONS *(continued)*

QFN24	SOIC28	Name	Description
15	21	LED1	LED String 1 Current Input. This pin is the open-drain output of an internal dimming control switch. Connect the LED String 1 cathode to this pin. If this string is not used, connect Vout to this pin.
16	22	OVP	Over-voltage Protection Input. Connect a resistor divider from output to this pin to program the OVP threshold. When this pin voltage reaches 1.23V, the MP3388 triggers OV Protection mode.
17	23	PGND2	Step-up Converter Power Ground.
18	24	PGND1	Step-up Converter Power Ground. PGND1 and PGND2 should be shorted externally.
19	28	SW2	Step-up Converter Power Switch Output. SW2 is the drain of the internal MOSFET switch. Connect the power inductor and output rectifier to SW2. SW2 can swing between GND and 50V. SW1 and SW2 should be shorted externally.
20	26	SW1	Step-up Converter Power Switch Output. SW1 is the drain of the internal MOSFET switch. Connect the power inductor and output rectifier to SW1. SW1 can swing between GND and 50V. SW1 and SW2 should be shorted externally.
21	1	VFAULT	Fault Disconnection Switch Driver Output. When the system starts up normally, this pin turns on the external PMOS. When the MP3388 is disabled, the external PMOS is turned off to disconnect the input and output.
22	2	COMP	Step-up Converter Compensation Pin. This pin is used to compensate the regulation control loop. Connect a capacitor or a series RC network from COMP to GND.
23	3	VIN	Supply Input. VIN supplies the power to the MP3388 chip. Drive VIN with a 4.5V to 25V power source. Must be locally bypassed.
24	4	VCC	The Internal 5V Linear Regulator Output. VCC provides power supply for the internal MOSFET switch gate driver and the internal control circuitry. Bypass VCC to GND with a ceramic capacitor. If VIN is less than 5.5V, apply an external 5V supply directly on VCC.
	15, 17, 25, 27	NC	No connect

TYPICAL PERFORMANCE CHARACTERISTICS

$V_{IN} = 15V$, 10 LEDs in series, 8 strings parallel, 20mA/string, unless otherwise noted.

Efficiency vs. Input Voltage

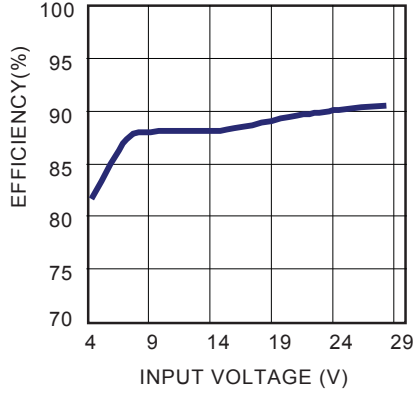

Steady State

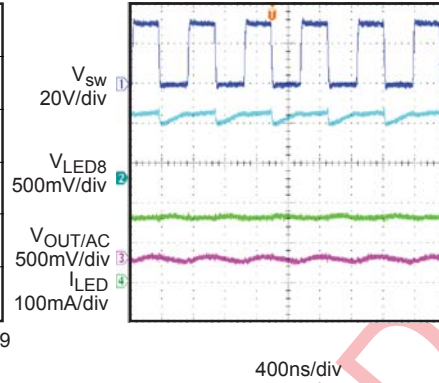

Vin Startup

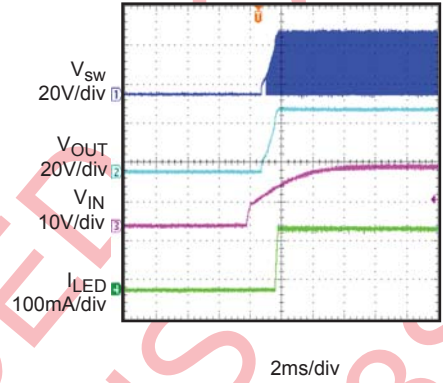

Ven Startup

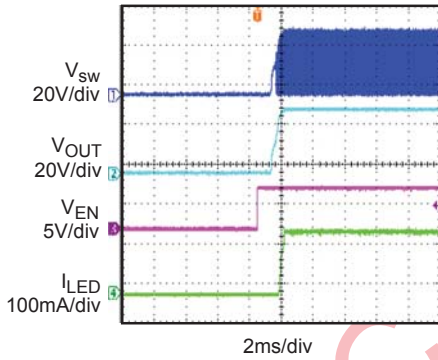

PWM Dimming

$f_{PWM} = 2kHz$, $D_{PWM} = 50\%$

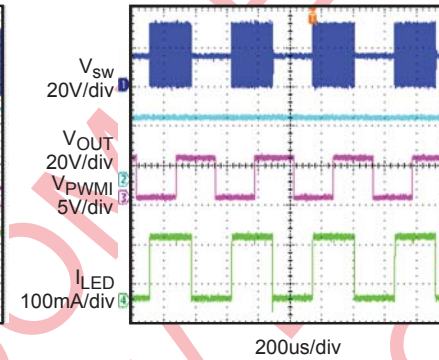

Open LED Protection

open all LED strings at working

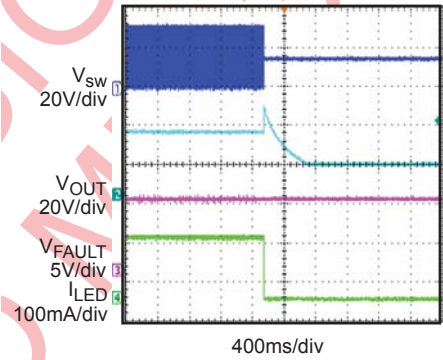

Short LED Protection

short Vout to LEDx at working

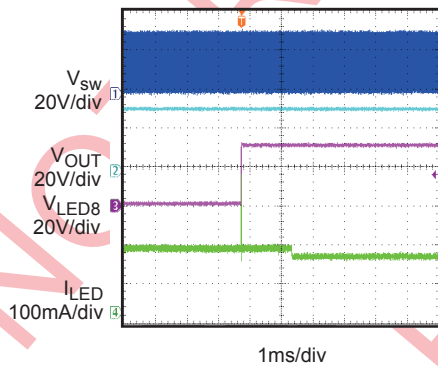

Short LED Protection

short Vout to GND at working

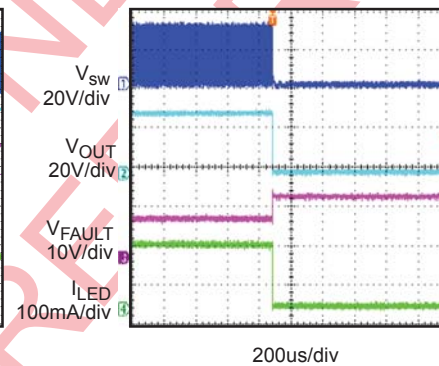

FUNCTION DIAGRAM

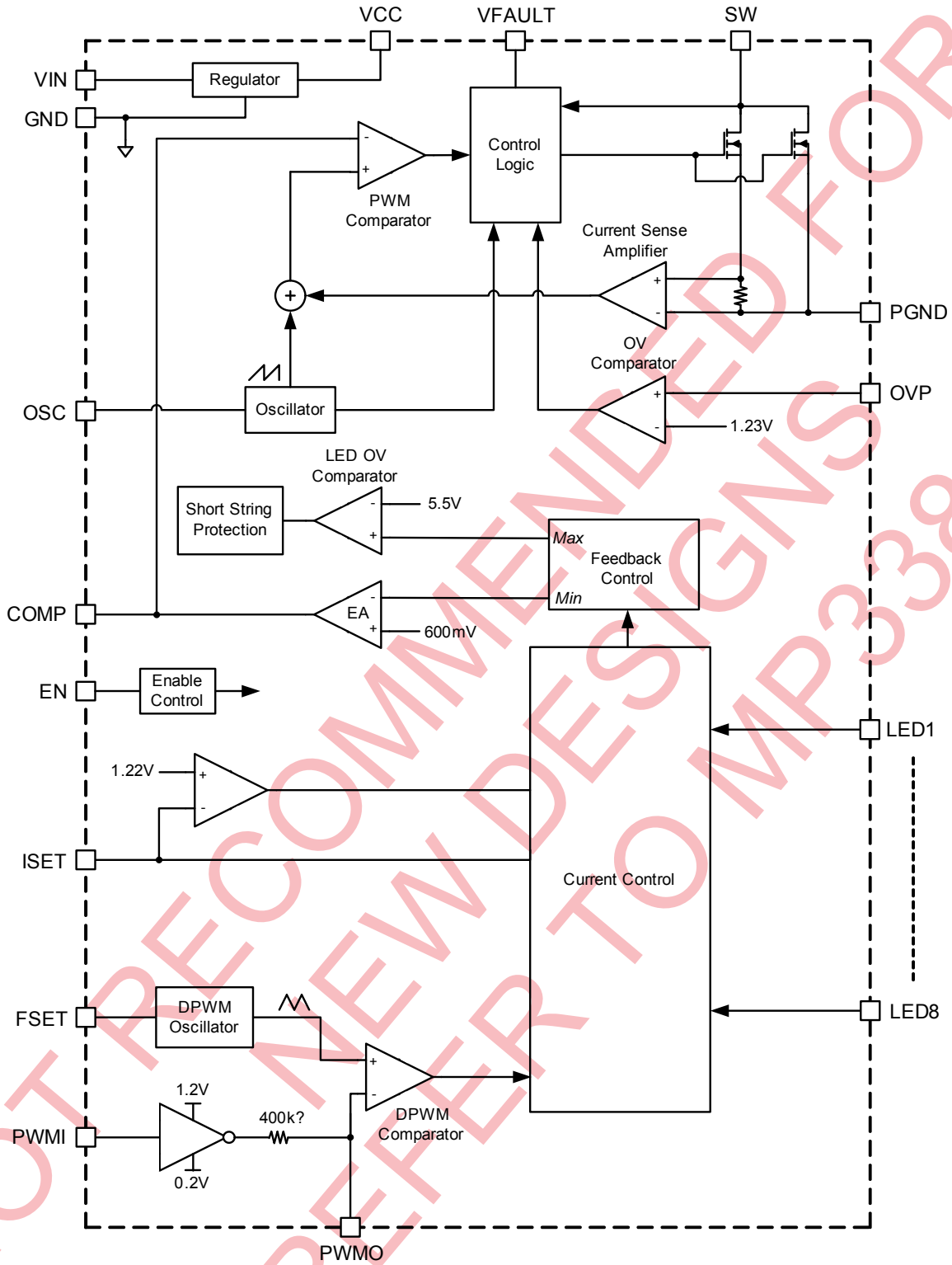

Figure 1—MP3388 Function Diagram

OPERATION

The MP3388 employs a constant frequency, peak current mode step-up converter and 8-channels regulated current sources to regulate the array of 8 strings white LEDs. The operation of the MP3388 can be understood by referring to the block diagram of Figure 1.

Internal 5V Regulator

The MP3388 includes an internal linear regulator (VCC). When VIN is greater than 5.5V, this regulator offers a 5V power supply for the internal MOSFET switch gate driver and the internal control circuitry. The VCC voltage drops to 0V when the chip shuts down. In the application of VIN smaller than 5.5V, tie VCC and VIN together. The MP3388 features Under Voltage Lockout. The chip is disabled until VCC exceeds the UVLO threshold. And the hysteresis of UVLO is approximately 200mV.

System Startup

When the MP3388 is enabled, the chip checks the topology connection first. The VFAULT pin drives the external Fault Disconnection PMOS to turn on slowly. And after 400us delay, the chip monitors the OVP pin to see if the Schottky diode is not connected or the boost output is short to GND. If the OVP voltage is lower than 70mV, the chip will be disabled and the external PMOS is turned off together. The MP3388 will also check other safety limits, including UVLO, and OTP after the OVP test is passed. If they are all in function, it then starts boosting the step-up converter with an internal soft-start.

It is recommended on the start up sequence that the enable signal comes after input voltage and PWM dimming signal established.

Step-up Converter

The converter operation frequency is selectable (1.25MHz or 625kHz), which is helpful for optimizing the external components sizes and improving the efficiency.

At the beginning of each cycle, the power FET is turned with the internal clock. To prevent sub-harmonic oscillations at duty cycles greater than 50 percent, a stabilizing ramp is added to the

output of the current sense amplifier and the result is fed into the PWM comparator. When this result voltage reaches the output voltage of the error amplifier (V_{COMP}) the power FET is turned off.

The voltage at the output of the internal error amplifier is an amplified signal of the difference between the 600mV reference voltage and the feedback voltage. The converter automatically chooses the lowest active LEDX pin voltage for providing enough bus voltage to power all the LED arrays.

If the feedback voltage drops below the 600mV reference, the output of the error amplifier increases. It results in more current flowing through the power FET, thus increasing the power delivered to the output. In this way it forms a close loop to make the output voltage in regulation.

At light-load or Vout near to Vin operation, the converter runs into the pulse-skipping mode, the FET is turned on for a minimum on-time of approximately 100ns, and then the converter discharges the power to the output in the remnant period. The FET will keep off until the output voltage needs to be boosted again.

Dimming Control

The MP3388 provides several PWM dimming methods: external PWM signal from PWMI pin or DC input PWM Dimming mode (see Figure 2). These methods results in PWM chopping of the current in the LEDs for all 8 channels to provide LED control.

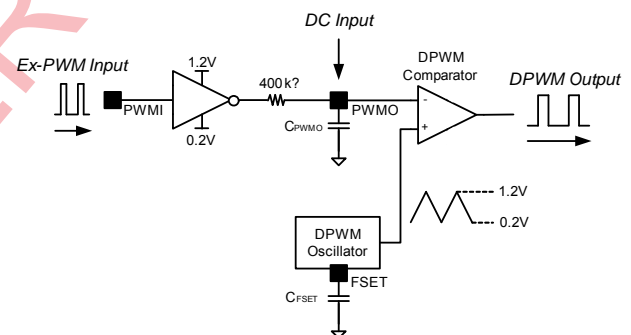

Figure 2—PWM Dimming Method

When applying a PWM signal to the PWMI pin, the MP3388 generates a DC voltage on PWMO pin which is reversely proportional to the duty cycle of the PWMI pin signal. By comparing the PWMO pin signal with the FSET pin triangle waveform, the converter gets a low frequency chopping signal that the duty cycle is same as the input signal. This low frequency chopping signal will modulate the LED current.

A DC analog signal can be directly applied to the PWMO pin to modulate the LED current. And the DC signal is then converted to a DPWM dimming signal at the setting oscillation frequency. The polarity is negative.

The brightness of the LED array is proportional to the duty cycle of the DPWM signal. The DPWM signal frequency is set by the cap at the FSET pin.

Open String Protection

The open string protection is achieved through the over voltage protection. If one or more strings are open, the respective LEDX pins are pulled to ground and the IC keeps charging the output voltage until it reach OVP threshold. Then the part will mark off the open strings whose LEDX pin voltage is less than 175mV. Once the mark-off operation completes, the remaining LED strings

will force the output voltage back into tight regulation. The string with the highest voltage drop is the ruling string during output regulation.

The MP3388 always tries to light at least one string and if all strings in use are open, the MP3388 shuts down the step-up converter. The part will maintain mark-off information until the part shuts down.

Short String Protection

The MP3388 monitors the LEDX pin voltage to judge if the short string occurs. If one or more strings are short, the respective LEDX pins will be pulled up to the boost output and tolerate high voltage stress. If the LEDX pin voltage is higher than 5.5V, the short string condition is detected on the respective string. When the short string fault (LEDX over-voltage fault) continues for greater than 1.6ms, the string is marked off and disabled. Once a string is marked off, its current regulation is forced to disconnect from the output voltage loop regulation. The marked-off LED strings will be shut off totally until the part restarts. If all strings in use are short, the MP3388 will shut down the step-up converter.

APPLICATION INFORMATION

Selecting the Switching Frequency

The switching frequency of the step-up converter is alternative for 1.25MHz or 625kHz. A bi-level Switching Frequency Selection (OSC) input sets the internal oscillator frequency for the step-up converter. Tie OSC pin to GND corresponds to the frequency 625kHz and tie OSC pin to VCC or floating corresponds to 1.25MHz.

Setting the LED Current

The LED string currents are identical and set through the current setting resistor on the ISET pin.

$$I_{LED} = 1000 \times 1.22V / (R_{SET} + 1k\Omega)$$

For $R_{SET} = 60.4k\Omega$, the LED current is set to 19.9mA. The ISET pin can not be open.

Setting the Over Voltage Protection

The open string protection is achieved through the over voltage protection (OVP). In some cases, an LED string failure results in the feedback voltage always zero. The part then keeps boosting the output voltage higher and higher. If the output voltage reaches the programmed OVP threshold, the protection will be triggered.

To make sure the chip functions properly, the OVP setting resistor divider must be set with a proper value. The recommended OVP point is about 1.3 times higher than the output voltage for normal operation.

$$V_{OVP} = 1.23V \times (R_1 + R_2) / R_2$$

Selecting Dimming Control Mode

The MP3388 provides 4 different dimming methods

1. PWM dimming mode with internal triangle waveform generator

Apply a 100Hz to 50kHz square waveform to the PWMI pin. The internal 400kΩ and external capacitor on PWMO pin filters the dimming signal to a DC voltage (0.2V~1.2V). Then the DC voltage is modulated to an internal PWM dimming signal whose frequency is set via the capacitor on FSET pin according to the equation:

$$f_{DPWM} = 3.5\mu F / C_{FSET}$$

The minimum recommended amplitude of the PWM signal is 2.1V (See Figure 3)

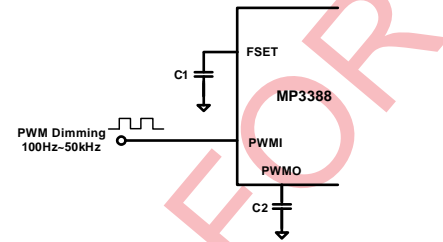

Figure 3—PWM Dimming with Internal Triangle Waveform Generator

2. Direct PWM dimming with positive logic

An external PWM dimming signal is directly employed to achieve PWM dimming control. Connect a 100kΩ resistor from FSET pin to GND and apply the 100Hz to 2kHz PWM dimming signal to PWMI pin. The minimum recommended amplitude of the PWM signal is 1.5V (See Figure 4).

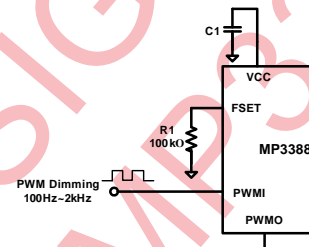

Figure 4—Direct PWM Dimming with Positive Logic

3. Direct PWM dimming with negative logic

It is similar to method 2. Apply a 100Hz to 2 kHz external square waveform to the PWMO pin for negative logic PWM dimming. The minimum recommended amplitude of the PWM signal is 1.5V (See Figure 5),

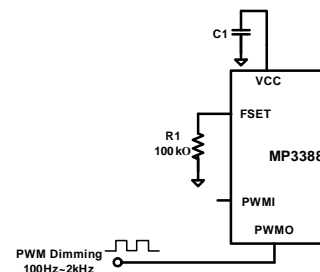

Figure 5—Direct PWM Dimming with Negative Logic

4. DC input PWM dimming

To apply DC input PWM dimming, apply an analog signal (range from 0.2V to 1.2V) to the PWMO pin to modulate the LED current directly. If the PWMO is applied with a DC voltage $0.2V$, the PWM duty cycle will be 100%. If the PWMO pin is applied with a DC voltage >math>1.2V</math>, the output will be 0% (See Figure 6). The capacitor on FSET pin set the frequency of internal triangle waveform.

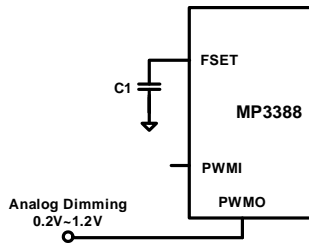

Figure 6—DC input PWM dimming

Selecting the Inductor

A 10 μ H (for 1.25MHz switching frequency) /22 μ H (for 625kHz switching frequency) inductor with a DC current rating of at least 40% higher than the maximum input current is recommended for most applications. For highest efficiency, the inductor’s DC resistance should be as small as possible.

Selecting the Input Capacitor

The input capacitor reduces the surge current drawn from the input supply and the switching noise from the device. The input capacitor impedance at the switching frequency should be less than the input source impedance to prevent high frequency switching current from passing through the input. Ceramic capacitors with X5R or X7R dielectrics are highly recommended because of their low ESR and small temperature coefficients. For most applications, a 4.7 μ F capacitor is sufficient.

Selecting the Output Capacitor

The output capacitor keeps the output voltage ripple small and ensures feedback loop stability. The output capacitor impedance should be low at the switching frequency. Ceramic capacitors with X7R dielectrics are recommended for their low ESR characteristics. For most applications, a 2.2 μ F ceramic capacitor will be sufficient.

Layout Considerations

Careful attention must be paid to the PCB board layout and components placement. Proper layout of the high frequency switching path is critical to prevent noise and electromagnetic interference problems. The loop of MP3388 SW to PGND pin (U1), output diode (D1), and output capacitor (C3) is flowing with high frequency pulse current. it must be as short as possible (See Figure 7).

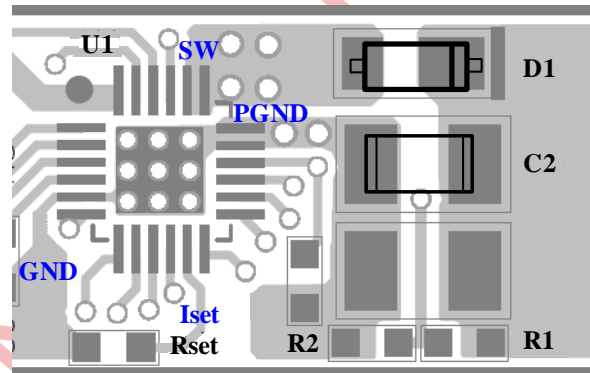
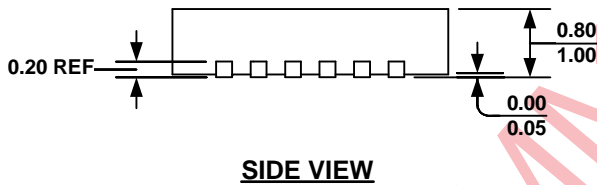
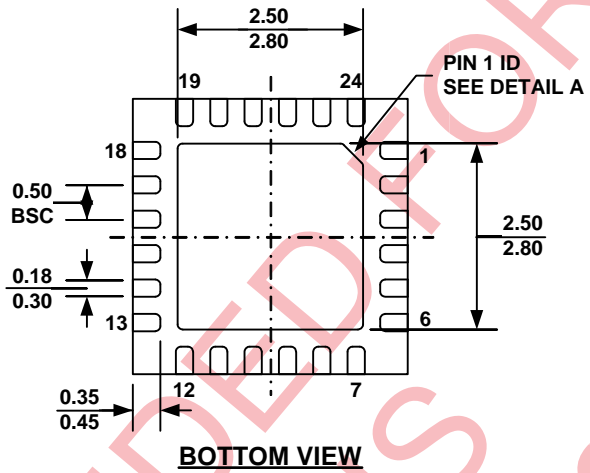
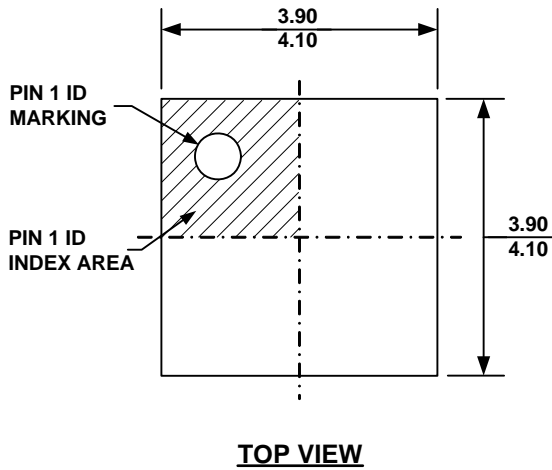

Figure 7—Layout Consideration

The IC exposed pad is internally connected to GND pin, and all logic signals are refer to the GND. The PGND should be externally connected to GND and is recommended to keep away from the logic signals.

PACKAGE INFORMATION

QFN24 (4mm x 4mm)



PIN 1 ID OPTION A
0.30x45° TYP.

PIN 1 ID OPTION B
R0.25 TYP.

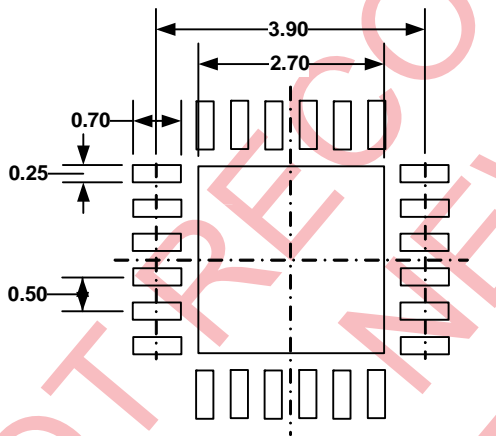

NOTE:

- 1) ALL DIMENSIONS ARE IN MILLIMETERS.
- 2) EXPOSED PADDLE SIZE DOES NOT INCLUDE MOLD FLASH.
- 3) LEAD COPLANARITY SHALL BE 0.10 MILLIMETER MAX.
- 4) DRAWING CONFIRMS TO JEDEC MO-220, VARIATION VGGD.
- 5) DRAWING IS NOT TO SCALE.

PACKAGE INFORMATION (continued)

SOIC28

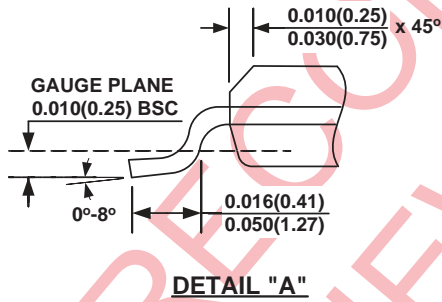
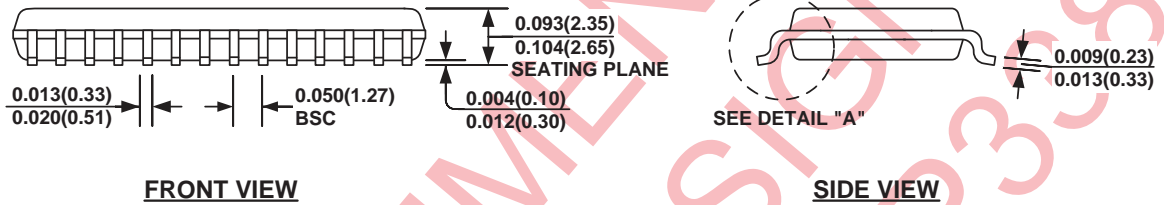
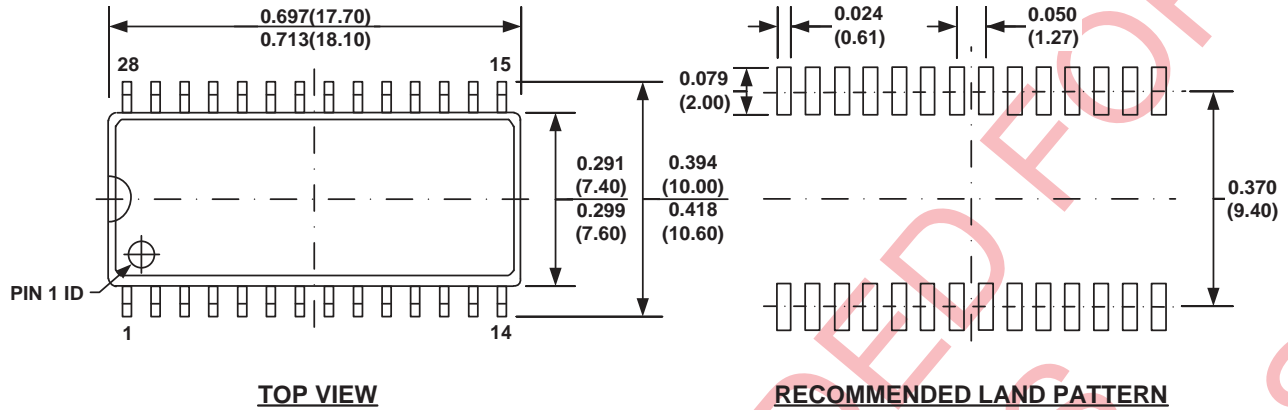

NOTE:

- 1) CONTROL DIMENSION IS IN INCHES. DIMENSION IN BRACKET IS IN MILLIMETERS.
- 2) PACKAGE LENGTH DOES NOT INCLUDE MOLD FLASH, PROTRUSIONS OR GATE BURRS.
- 3) PACKAGE WIDTH DOES NOT INCLUDE INTERLEAD FLASH OR PROTRUSIONS.
- 4) LEAD COPLANARITY (BOTTOM OF LEADS AFTER FORMING) SHALL BE 0.10 MILLIMETERS MAX.
- 5) DRAWING CONFORMS TO JEDEC MS-013, VARIATION AE.
- 6) DRAWING IS NOT TO SCALE.

NOTICE: The information in this document is subject to change without notice. Users should warrant and guarantee that third party Intellectual Property rights are not infringed upon when integrating MPS products into any application. MPS will not assume any legal responsibility for any said applications.